



DIRECTORY

目录 MEIYALVCAI

01-34	壁门系列	122	豪华中空银弧大折叠门
35-47	铝框门系列	123	有轨小折叠门系列
48-52	铝合金玻璃门框	124	圆弧小折叠门系列
53-68	晶钢门系列	125	无轨小折叠门系列
69-100	铝封边系列	126	新型大推拉门系列
101-107	封边拉手	127-131	中空平开门系列
108-109	生态门系列	132-134	多功能包套系列
110-113	高隔间系列	135-136	经济型70、80系列推拉门
114-115	LED灯具系列	137	豪华中空平开门系列
116	豪华中空大折叠门系列	138	欧式衣帽间系列
117-121	豪华中空推拉(吊趟)门系列		

樱花系列新款移门



<p>A-B7701T 0.734kg/m</p>	<p>A-B7702T 0.374kg/m</p>	<p>A-B7703 0.382kg/m</p>	<p>A-B7704 0.708kg/m</p>
<p>A-B7705 0.965kg/m</p>	<p>A-B7706 0.671kg/m</p>	<p>A-B7707 0.724kg/m</p>	<p>A-B7709 0.827kg/m</p>
<p>A-B7709AP 0.437kg/m</p>	<p>A-B7714 2.575kg/m</p>	<p>A1363 0.401kg/m</p>	<p>A1330P 0.149kg/m</p>
<p>A650 0.474kg/m</p>	<p>A1328 0.362kg/m</p>	<p>A1329P 0.339kg/m</p>	

樱花系列新款移门

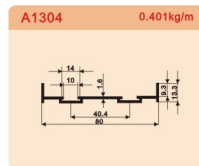
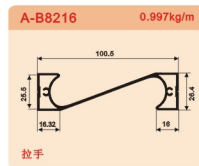
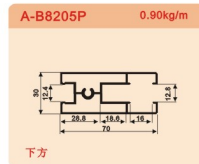
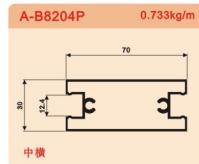
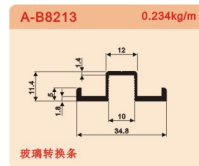
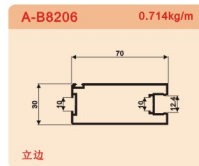
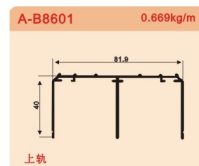
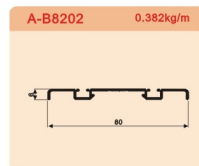
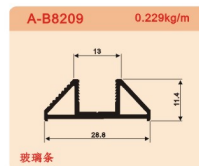
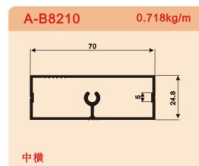
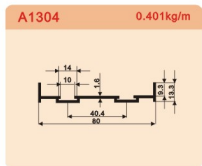
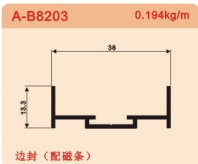
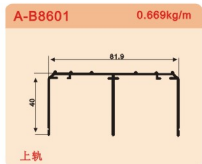
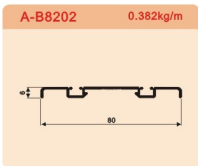
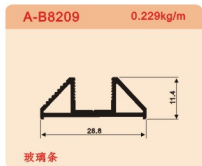
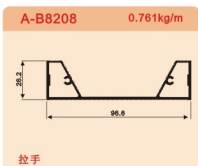
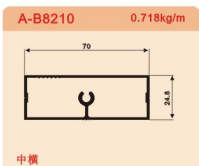
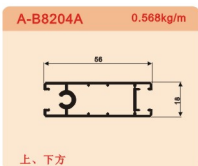
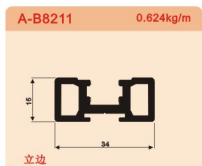

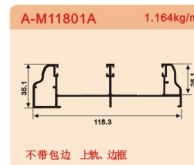
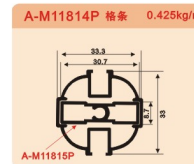
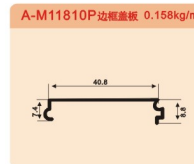
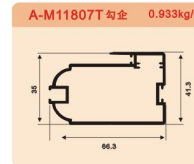
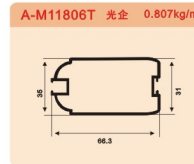
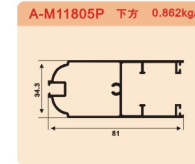
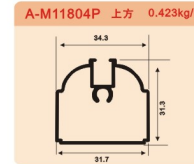
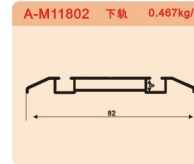
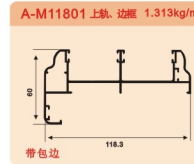
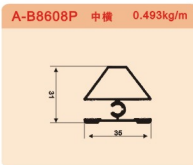
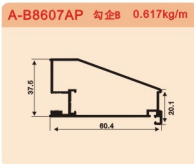
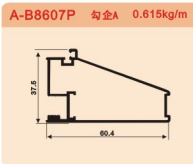
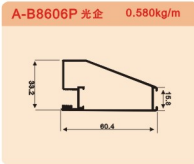
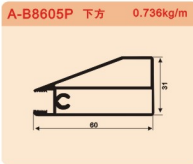
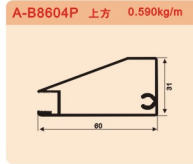
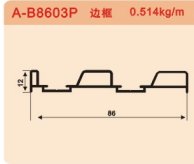
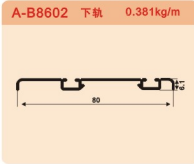
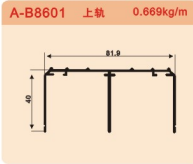



A-B8301P 上轨 0.642kg/m

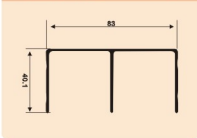

A-B8302P 双轮下轨 0.541kg/m

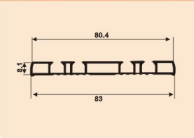

A-B8303P 边框 0.695kg/m

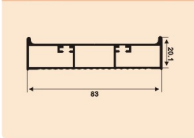

A-B8304P 上方 0.524kg/m

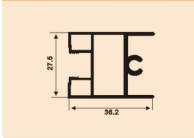

A-B8305P 下方 0.540kg/m

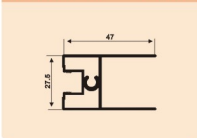

A-B8306 光企 0.804kg/m

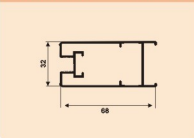

A-B8307 勾企 0.882kg/m

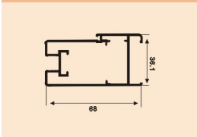

A-B8308P 中横 0.851kg/m

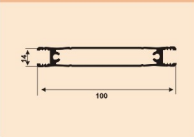

A-B8310P 光勾企盖板 0.145kg/m

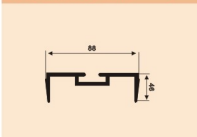

A-M5701 上轨、边框 0.963kg/m

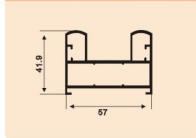

A-M5705P 格条一 0.300kg/m

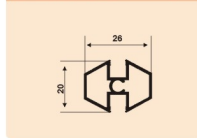

A-M5704T 平面光企 1.114kg/m

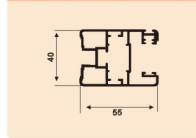

A-M5702 下轨 0.511kg/m

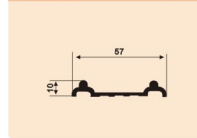

A1030 弧形光企 0.957kg/m

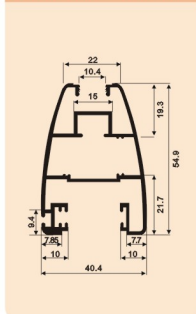

A-M5706 0.275kg/m

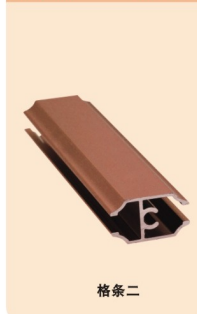

<p>F88-17 0.176kg/m</p>	<p>F99-11 0.84kg/m</p>	<p>F99-12 0.548kg/m</p>	<p>F88-32 0.73kg/m</p>
<p>F88-31 0.428kg/m</p>	<p>F88-19 0.810kg/m</p>	<p>F99-9 0.323kg/m</p>	<p>F88-20 0.507kg/m</p>
<p>F88-39 0.346kg/m</p>	<p>F88-10H 0.132kg/m</p>	<p>F88-10A 0.3kg/m</p>	<p>F88-38 0.64kg/m</p>
<p>F88-42 0.484kg/m</p>	<p>F88-40A 0.29kg/m</p>	<p>F88-40 0.55kg/m</p>	<p>F88-41 0.45kg/m</p>

明装趟轮

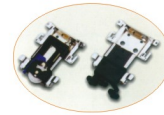

暗装趟轮



第六代



第七代



第八代



第九代

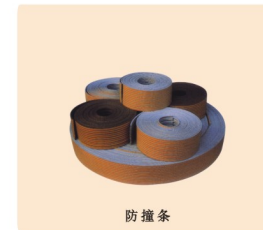

第十代优质双子轮



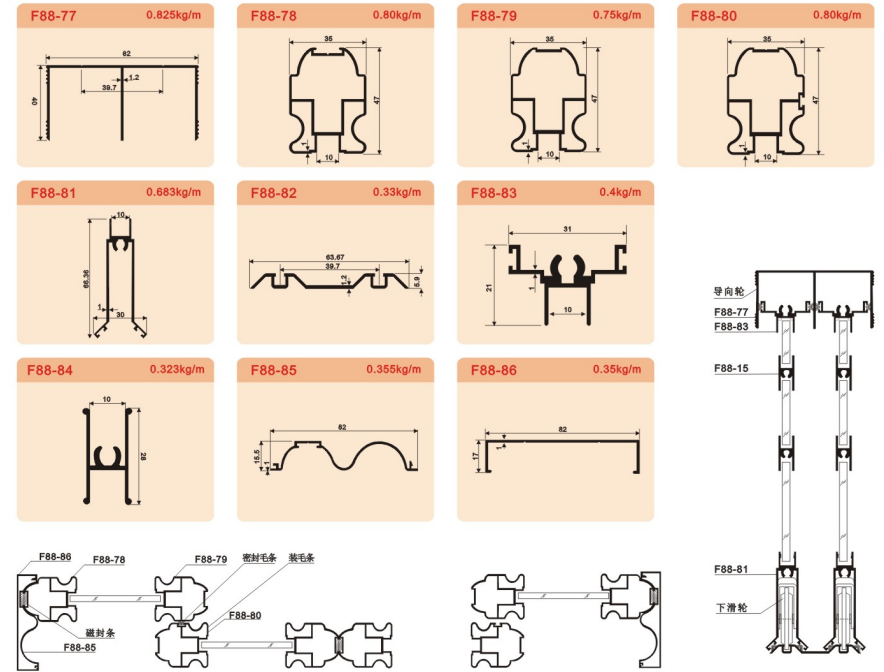
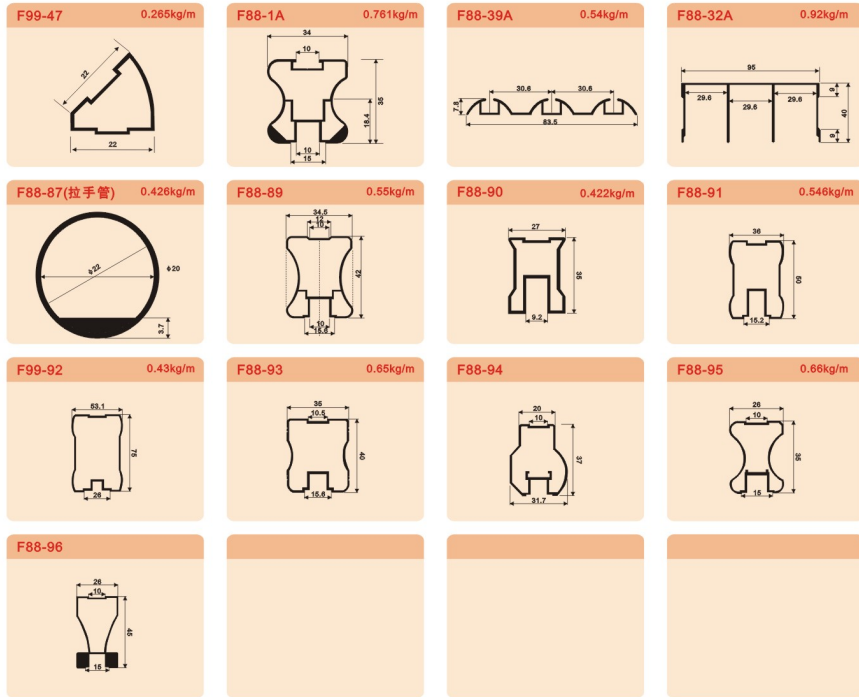

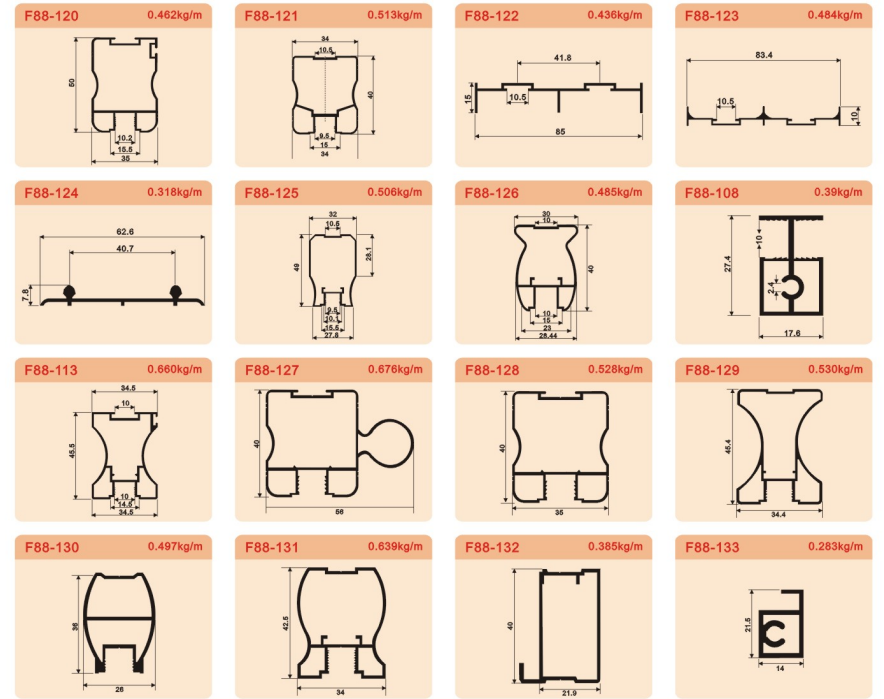
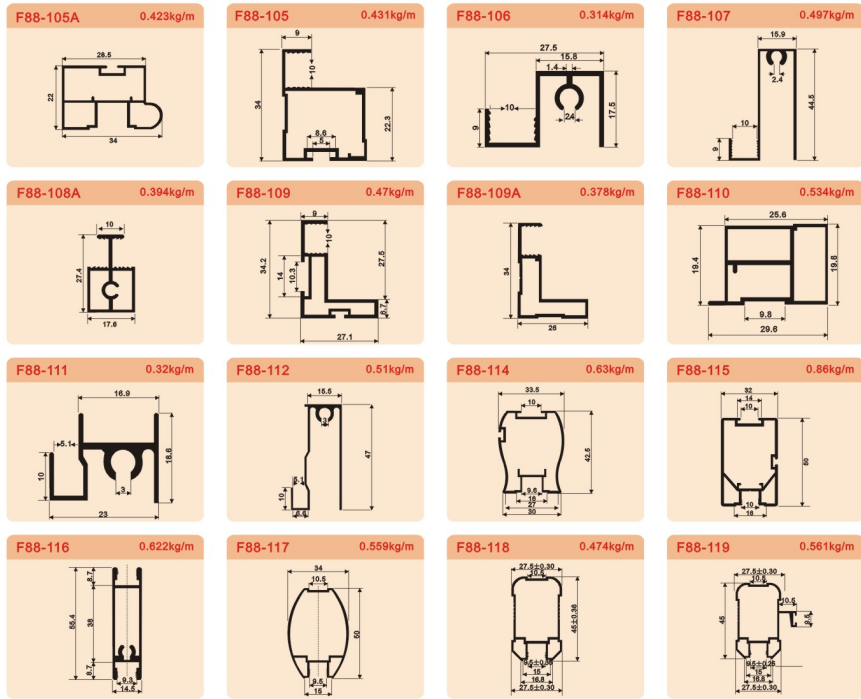

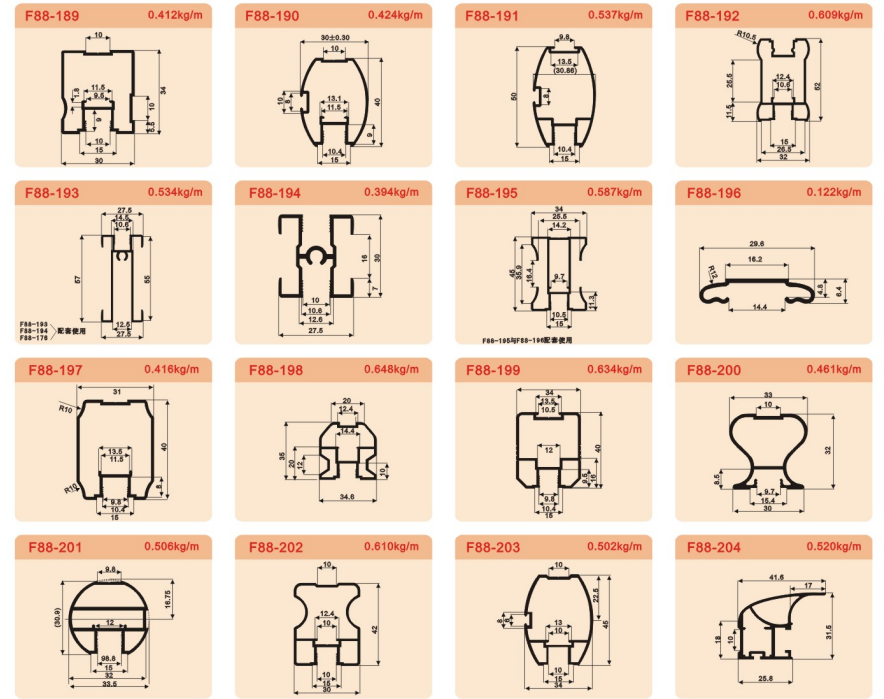
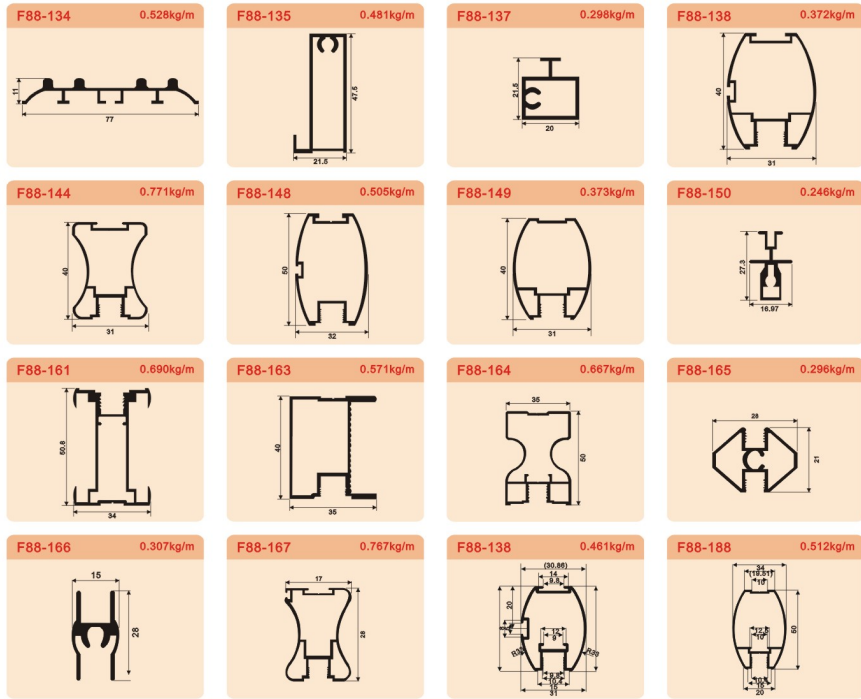





F88-270 0.536kg/m 	F88-271 0.402kg/m 	A934 0.462kg/m 	A933 0.282kg/m
A967L 0.421kg/m 	A968P 0.488kg/m 	A981 0.863kg/m 	A982T 0.698kg/m
A1155L 0.534kg/m 	A1156L 0.433kg/m 	A1150 0.468kg/m 	A1151 0.300kg/m
A1147T 0.740kg/m 	A1154 	A1158L 0.311kg/m 	A1183L 0.398kg/m

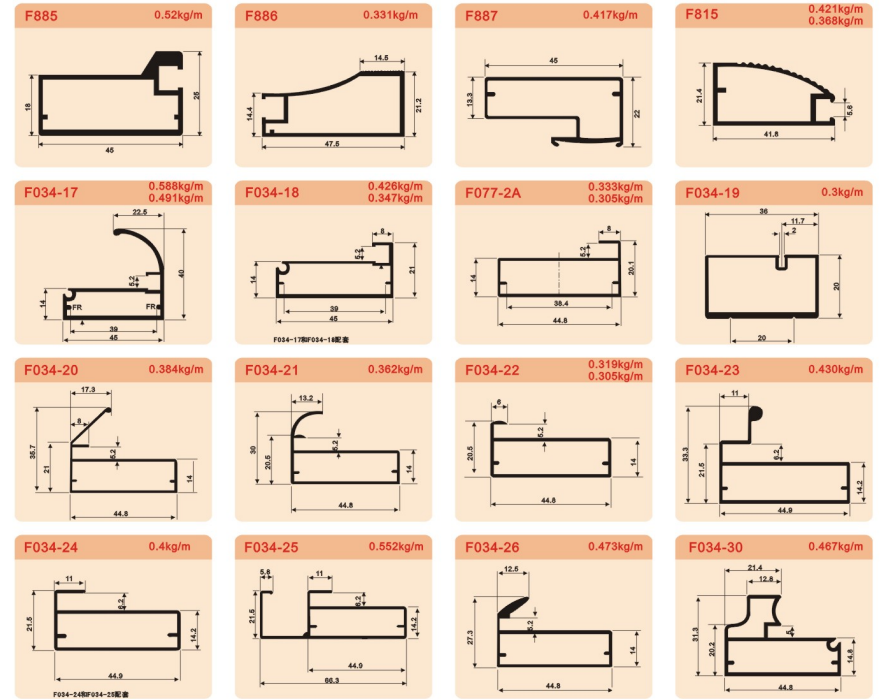
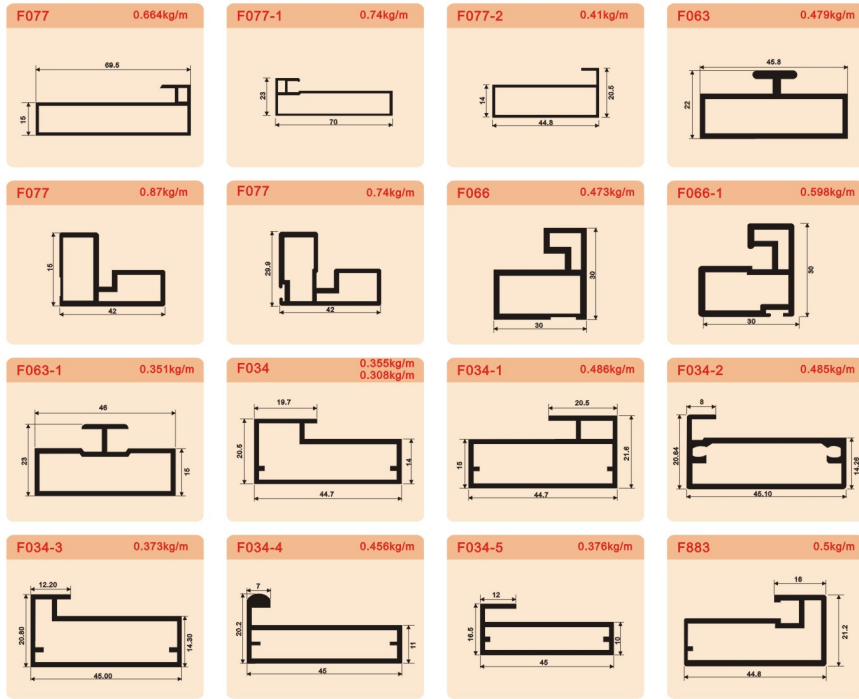

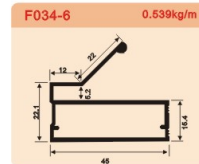
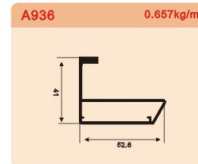
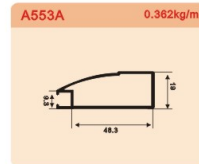
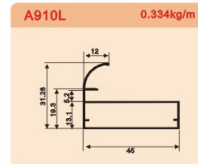
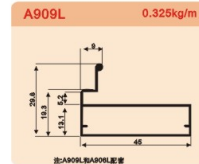
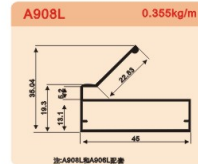
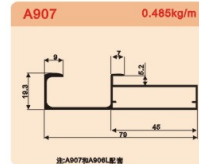
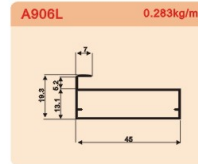
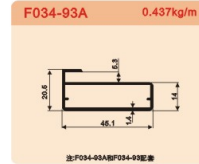
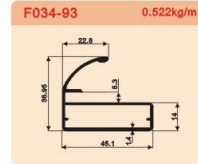
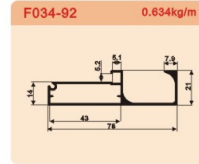
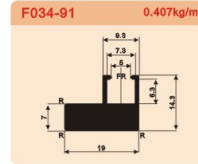
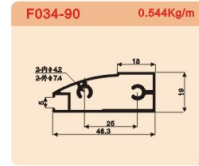
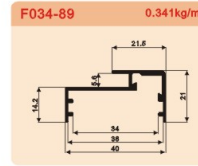
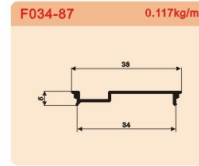
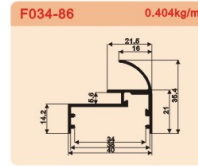
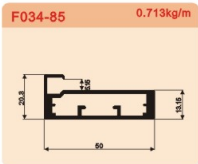
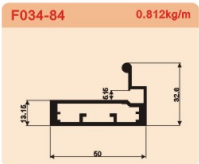
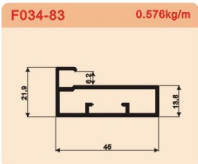
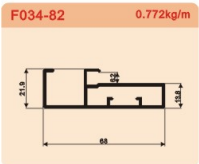
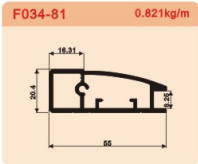
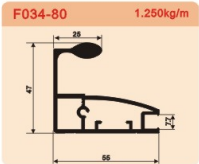
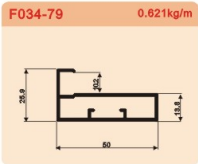
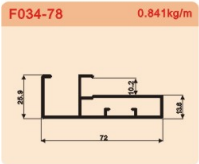
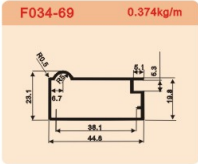
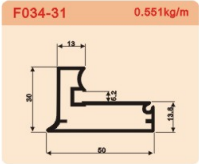
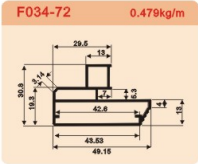
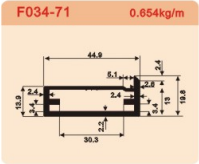
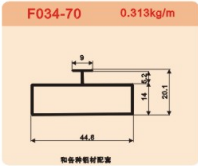
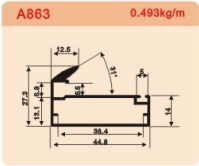
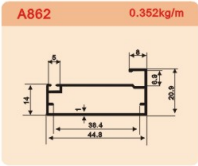
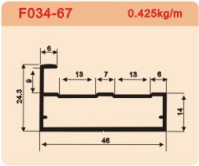

XBG-108 1.111kg/m 	XBG-109 0.493kg/m 	XBG-110 0.263kg/m 	XBG-111 0.904kg/m
XBG-112 0.858kg/m 	XBG-113 0.791kg/m 	XBG-114 0.665kg/m 	XBG-115 0.636kg/m
XBG-116 0.923kg/m 	XBG-117 0.701kg/m 	XBG-118 0.381kg/m 	XBG-119 0.916kg/m
XBG-120 0.388kg/m 	XBG-121 0.633kg/m 	XBG-122 0.724kg/m 	XBG-123 0.327kg/m

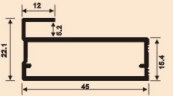
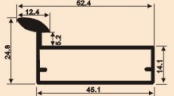
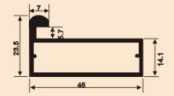
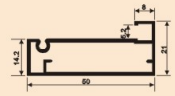
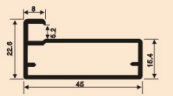
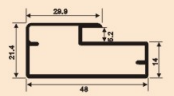
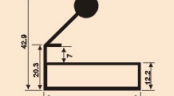
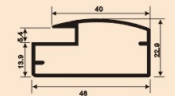
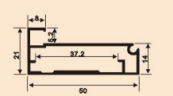
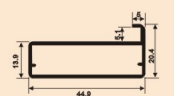
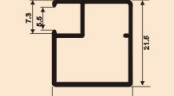

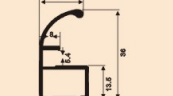
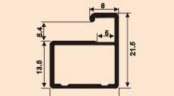
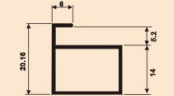
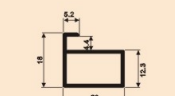

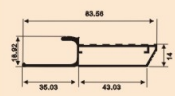
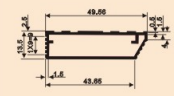
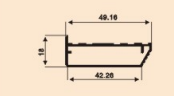
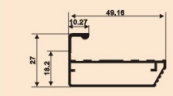

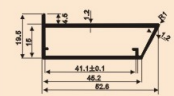
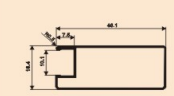
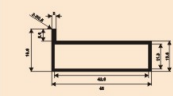
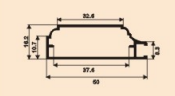
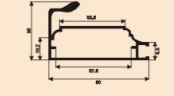
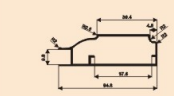
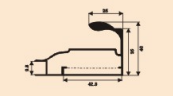
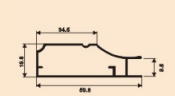
F034-7 0.443kg/m 	F034-8 0.497kg/m 	F034-9 0.449kg/m 	F034-10 0.420kg/m 
F034-11 0.443kg/m 0.539kg/m 	F034-12 0.488kg/m 0.373kg/m 	F034-13 0.686kg/m 	F034-14 0.477kg/m 
F034-15 0.488kg/m 	F034-16 0.411kg/m 	F035A 0.25kg/m 	F035-3 0.275kg/m 
F035-7 0.339kg/m 	F035-8 0.198kg/m 	F035-10 0.194kg/m 	F035-11 0.243kg/m 

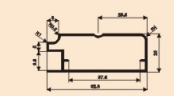
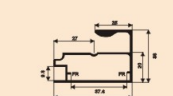
A911 0.600kg/m 	F034-75 0.388kg/m 	A401 0.389kg/m 	A841 0.468kg/m 
A1017 0.516kg/m 	F034-68 0.452kg/m 	A793L 0.308kg/m 	A1127 0.411kg/m 
A1134P 0.326kg/m 	A1135P 0.563kg/m 	A1137 0.417kg/m 	A1145 0.794kg/m 
A1136 0.394kg/m 	A1144 0.785kg/m 	A1138 0.371kg/m 	A1146 0.646kg/m 

<p>A1268 0.557kg/m</p>	<p>A1269 0.524kg/m</p>	<p>A1270 0.669kg/m</p>	<p>A1271 0.603kg/m</p>
<p>A1272 0.459kg/m</p>	<p>A1273 0.600kg/m</p>	<p>A1331 0.421kg/m</p> <p>注: A1331与A1332配套使用</p>	<p>A1332 0.543kg/m</p> <p>注: A1332与A1331配套使用</p>
<p>A1333 0.739kg/m</p> <p>注: A1333与P034-08配套使用</p>	<p>A1334 0.529kg/m</p> <p>注: A1334与P034-08配套使用</p>	<p>A1335 0.458kg/m</p> <p>注: A1335与A1337配套使用</p>	<p>A1336 0.662kg/m</p> <p>注: A1336与P034-08配套使用</p>
<p>A1337 0.601kg/m</p> <p>注: A1337与A1336配套使用</p>	<p>A1342 0.501kg/m</p> <p>注: A1342与A1343配套使用</p>	<p>A1343 0.707kg/m</p> <p>注: A1343与A1342配套使用</p>	<p>A1373 0.363kg/m</p>

<p>A1376L 0.300kg/m</p>	<p>A1384 0.578kg/m</p>	<p>A1385 0.428kg/m</p>	<p>A1392 0.448kg/m</p>
<p>A1393 0.452kg/m</p>	<p>A1394 0.481kg/m</p>	<p>A1510 0.425kg/m</p>	<p>A1127 0.411kg/m</p>
<p>A1537 0.247kg/m</p>	<p>A1538 0.409kg/m</p>	<p>A1128 0.656kg/m</p>	<p>A1148 0.400kg/m</p>
<p>A1149 0.476kg/m</p>	<p>A1211 0.425kg/m</p>	<p>A1223 0.317kg/m</p>	<p>A1540 0.538kg/m</p>

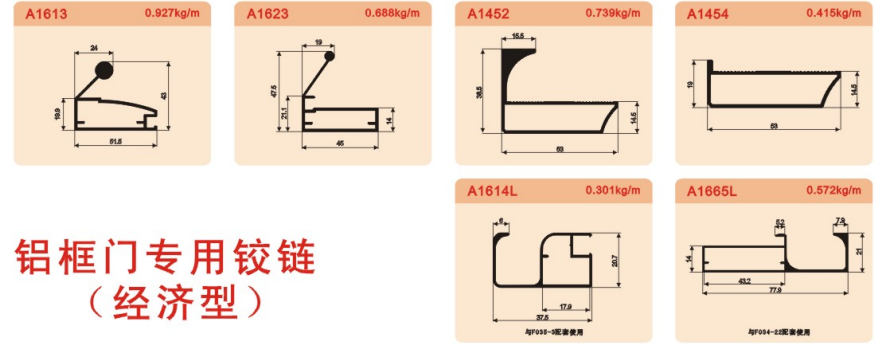
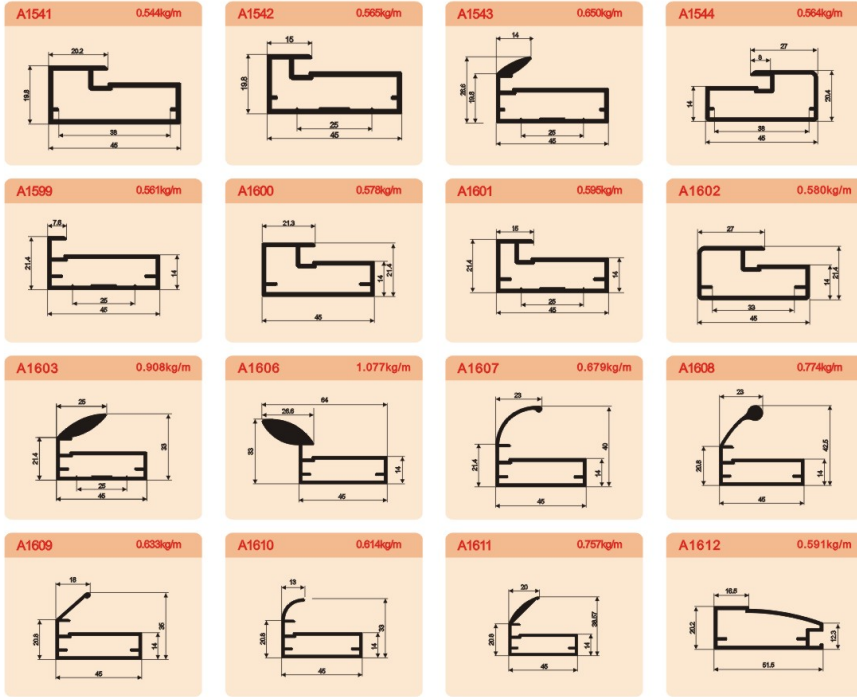

铝框门专用铰链 (经济型)



Hydraulic Hinge Series
液压阻尼铰链系列



液压阻尼铰链



液压阻尼铰链



直弯铰链



中弯铰链



大弯铰链



直弯铰链



中弯铰链



大弯铰链

PRECISION METAL

铝合金玻璃门框

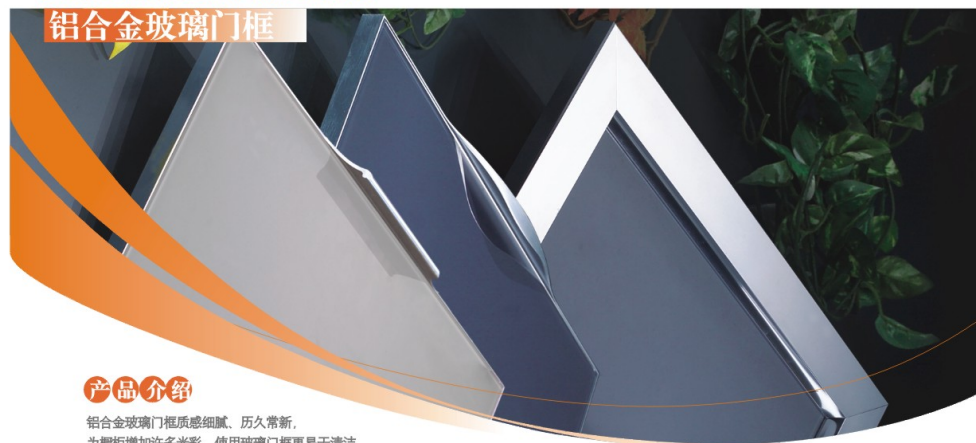

产品介绍

铝合金玻璃门框质感细腻、历久常新，
为橱柜增加许多光彩。使用玻璃门框更易于清洁，
健康环保无异味，更不必为受潮变形而担心。
自带拉手铝门框更能体现出整体感，
使之流露出一股浓厚的现代气息，是橱柜的流行元素之一。

PRODUCT INTERPRET

Aluminum glass door frame and delicate texture, often lasting new
Many additional luster to the cabinet. Using the glass door easier to clean, No smell,
health and environmental protection do not have to worry about damp deformation.
Comes more able to handle aluminum door frames reflect the overall sense,
Showing a surge of strong modern flavor, is one of the popular elements of the cabinets.

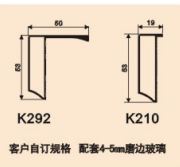

客户自订规格 配套4-5mm磨边玻璃

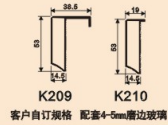
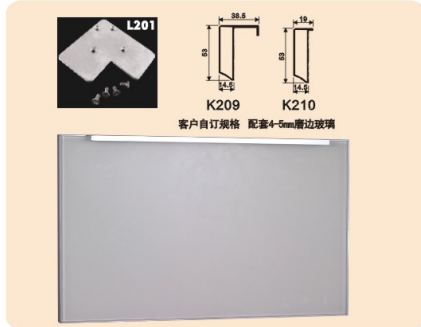

客户自订规格 配套4-5mm磨边玻璃

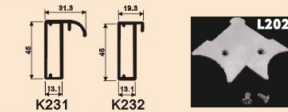
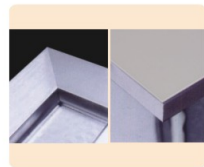

客户自订规格 配套4-5mm磨边玻璃

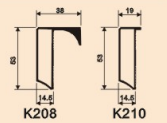

客户自订规格 配套4-5mm磨边玻璃

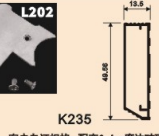

客户自订规格 配套3-4mm磨边玻璃

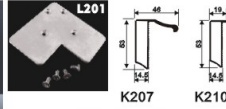
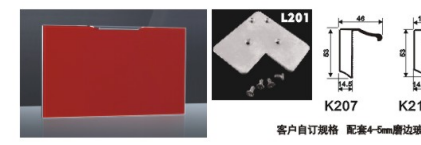

客户自订规格 配套4-5mm磨边玻璃

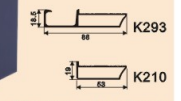
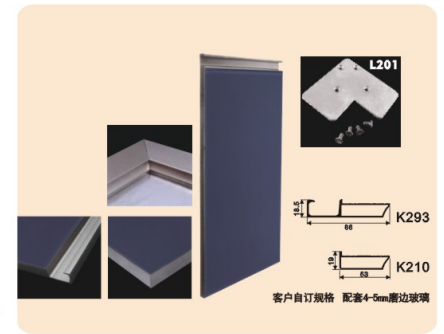

客户自订规格 配套4-5mm磨边玻璃

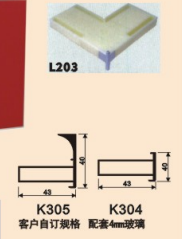
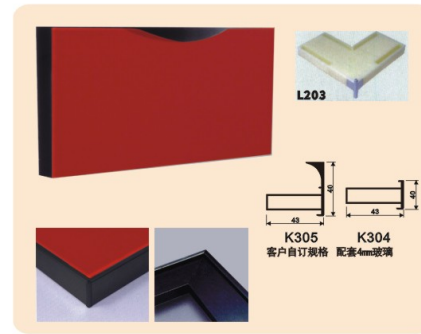

客户自订规格 配套4mm玻璃

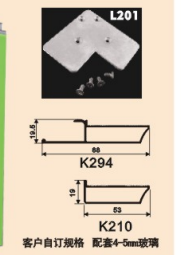
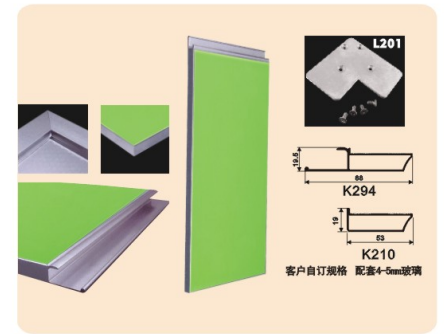

客户自订规格 配套4-5mm玻璃



晶钢门D型系列

A849 晶钢门D型 0.332kg/m

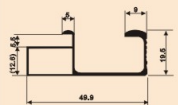

A849B 0.394kg/m

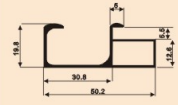

A849C 0.462kg/m

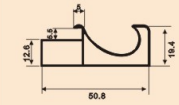

A851L 晶钢门D型 0.257kg/m

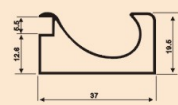

A848L 晶钢门D型 0.225kg/m

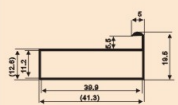

A850L 晶钢门D型 0.142kg/m

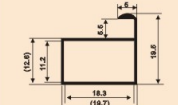

电镀角 (大)



电镀角 (小)



全增配A849C



大内角



小内角

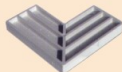

大直角



铰链垫块

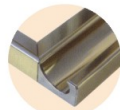
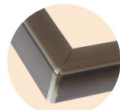
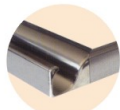

晶钢门E型系列

A845L 晶钢门E型 0.310kg/m

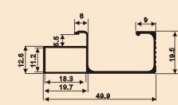

A844L 晶钢门E型 0.224kg/m

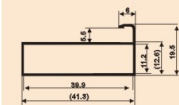

A843L 晶钢门E型 0.141kg/m

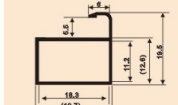

A846L 晶钢门E型 0.257kg/m

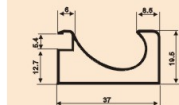

大直角



铰链垫块



小内角



电镀大内角

晶钢门F型系列



F034-A1 0.462kg/m

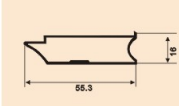

F034-A2 0.462kg/m

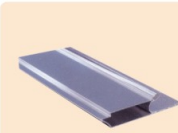
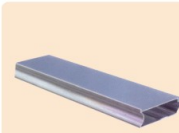
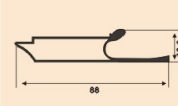

晶钢门F系列专用角码



晶钢门H型系列

<p>F034-A6 0.213kg/m</p>	<p>F034-A5 0.462kg/m</p>	<p>F034-A4 0.462kg/m</p>	<p>F034-A3 0.353kg/m</p>
<p>F034-A3/A4/A5使用效果</p>			
<p>F034-A7/A8使用效果</p>		<p>F034-A7 0.326kg/m</p>	<p>F034-A8 0.072kg/m</p>

晶钢门G型系列

<p>F034-A9 0.310kg/m</p>	<p>F034-A10 0.350kg/m</p>	<p>F034-A11 0.126kg/m</p>	<p>A1113 0.604kg/m</p>
<p>F034-A12 0.062kg/m</p> <p>门框饰条一</p>	<p>F034-A13 0.275kg/m</p> <p>门框饰条二</p>	<p>F034-A14 0.199kg/m</p> <p>门框饰条三</p>	<p>F034-A15 0.673kg/m</p> <p>门框扶手</p>
<p>圆形拉手规格: 40cm 100cm 150cm 192cm 320cm</p>	<p>七字形拉手规格: 40cm 100cm 150cm 192cm 320cm</p>		<p>F034-A10使用效果图</p>



MY0710 黑色拉丝
夹5厘背板

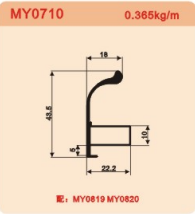

MY0710 0.366kg/m

配: MY0819 MY0820

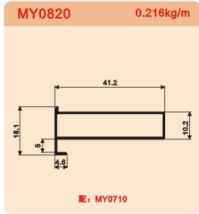

MY0820 0.216kg/m

配: MY0710

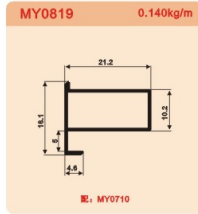

MY0819 0.140kg/m

配: MY0710



MY0818 黑色拉丝
夹5厘背板



MY0818 0.354kg/m

配: MY0634 MY0635

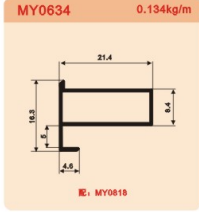

MY0634 0.134kg/m

配: MY0818

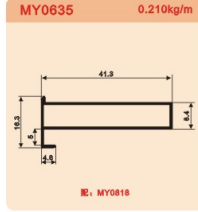

MY0635 0.210kg/m

配: MY0818



MY0824 亮光拉丝
夹5厘背板

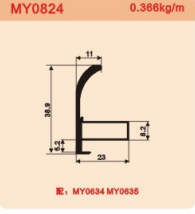

MY0824 0.366kg/m

配: MY0634 MY0635

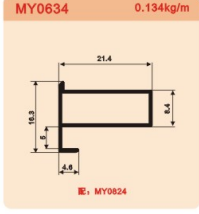

MY0634 0.134kg/m

配: MY0824

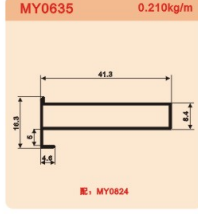

MY0635 0.210kg/m

配: MY0824



MY0826 黑色拉丝
夹5厘背板

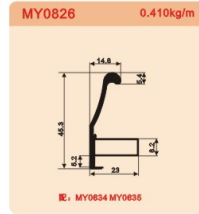

MY0826 0.410kg/m

配: MY0634 MY0635

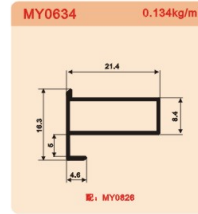

MY0634 0.134kg/m

配: MY0826

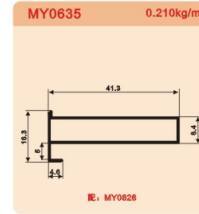

MY0635 0.210kg/m

配: MY0826



MY0825 磨砂香槟
夹3厘背板

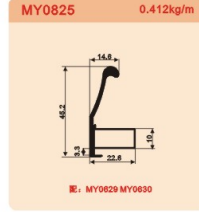

MY0825 0.412kg/m

配: MY0829 MY0630

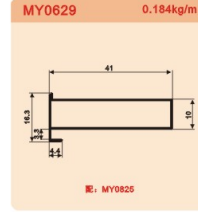

MY0629 0.184kg/m

配: MY0825

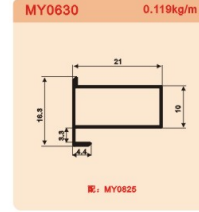

MY0630 0.119kg/m

配: MY0625

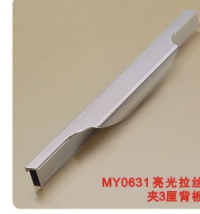

MY0631 亮光拉丝
夹3厘背板

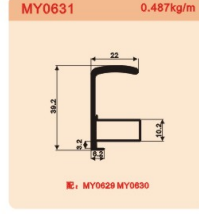

MY0631 0.487kg/m

配: MY0629 MY0630

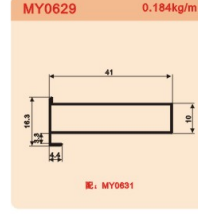

MY0629 0.184kg/m

配: MY0631

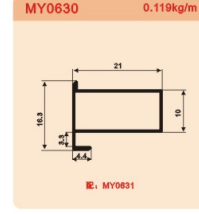

MY0630 0.119kg/m

配: MY0631



MY0632 磨砂香槟夹3厘背板

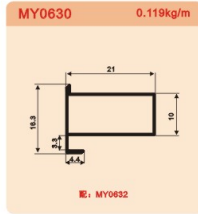
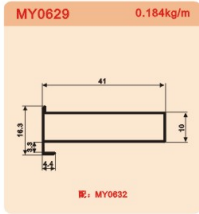
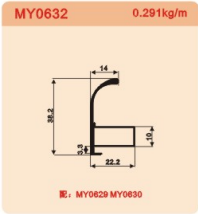

MY0633 黑色拉丝夹3厘背板

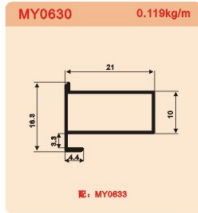
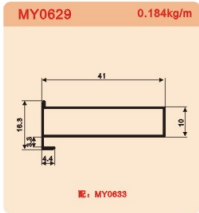
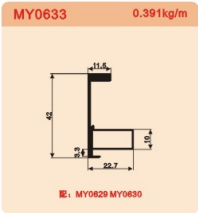

MY0662 亮光拉丝夹3厘背板

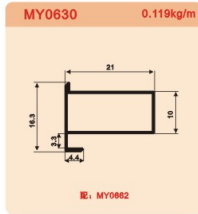
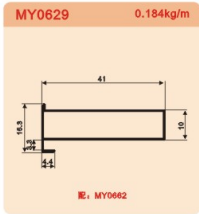

MY0823 磨砂香槟夹3厘背板

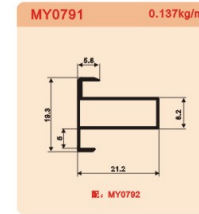
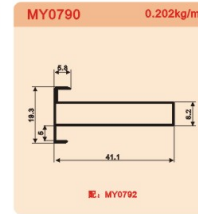
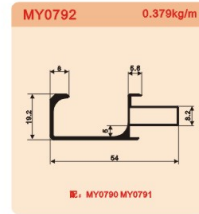
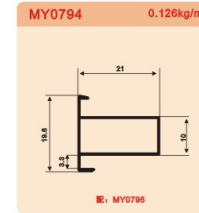
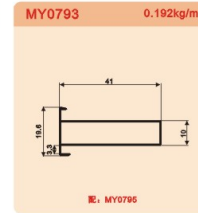
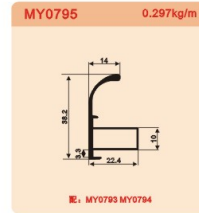
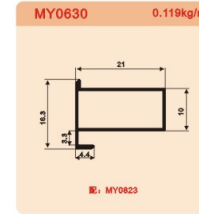
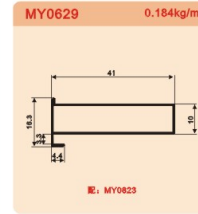
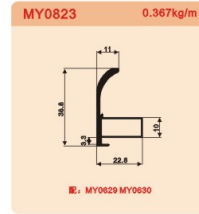

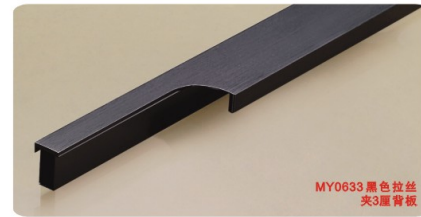
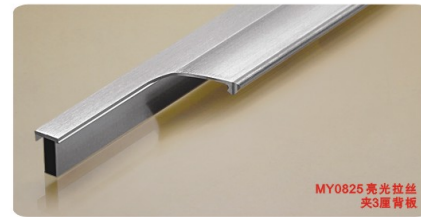
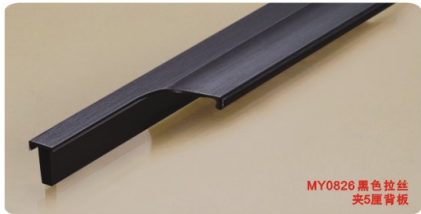
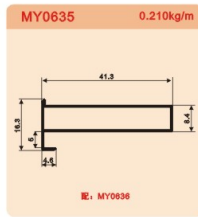
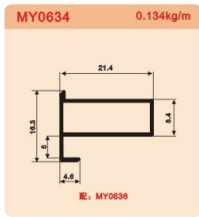
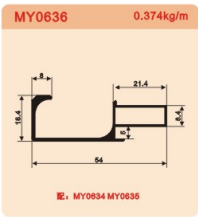
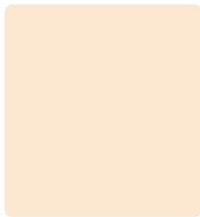



<p>MY0830 0.115kg/m</p> <p>配: 6MM玻璃 MY0832 MY0833</p>	<p>MY0831 0.179kg/m</p> <p>配: 6MM玻璃 MY0832 MY0833</p>	<p>MY0832 0.280kg/m</p> <p>配: 6MM玻璃 MY0830 MY0831</p>	<p>MY0833 0.342kg/m</p> <p>配: 6MM玻璃 MY0830 MY0831</p>
<p>MY0800 0.299kg/m</p> <p>配: MY0798 MY0799</p>	<p>MY0799 0.153kg/m</p> <p>配: MY0800</p>	<p>MY0801 0.328kg/m</p> <p>配: MY0798 MY0799</p>	<p>MY0802 0.282kg/m</p> <p>配: MY0798 MY0799</p>
<p>MY0798 0.095kg/m</p> <p>配: MY0800</p>	<p>MY-0803 0.170kg/m</p> <p>配: MY0805 MY0806</p>	<p>MY-0804 0.110kg/m</p> <p>配: MY0805 MY0806</p>	<p>MY-0805 0.271kg/m</p> <p>配: MY0803 MY0804</p>
<p>MY-0806 0.375kg/m</p> <p>配: MY0803 MY0804</p>	<p>MY-8047 0.124kg/m</p>	<p>MY-8048 0.194kg/m</p>	<p>MY-8049 0.348kg/m</p>

<p>MY-4340-3B 0.111kg/m</p>	<p>MY-4341-3B 0.174kg/m</p>	<p>MY-8063 0.194kg/m</p>	<p>MY-4340C 0.098kg/m</p>
<p>MY-4341C 0.171kg/m</p>	<p>MY-4343C 0.205kg/m</p>	<p>MY-4340F 0.088kg/m</p>	<p>MY-4341F 0.14kg/m</p>
<p>MY-4343F 0.17kg/m</p>	<p>MY-4340-3B 0.111kg/m</p>	<p>MY-4341-3B 0.174kg/m</p>	<p>MY-4343-3B 0.189kg/m</p>
<p>MY-4341-3 0.209kg/m</p>	<p>MY-4342-3 0.286kg/m</p>	<p>MY-4340-3 0.132kg/m</p>	<p>MY-4343-3 0.233kg/m</p>



MY-4344-3 0.324kg/m 	MY-4345-3 0.278kg/m 	MY-4347 0.51kg/m 	MY-4348 0.29kg/m
MY-1041 0.11kg/m 	MY-1042 0.174kg/m 	MY-1043 0.203kg/m 	MY-082 0.163kg/m
MY-075 0.304kg/m 	MY-081 0.102kg/m 	MY-8050 0.286kg/m 	MY-8041 0.159kg/m
MY-8042 0.1kg/m 	MY-8042 0.191kg/m 		

A724 0.517kg/m 	A725 0.085kg/m 	A726 0.117kg/m 	A727 0.789kg/m
A728 0.316kg/m 	A731 0.343kg/m 	A741 0.432kg/m 	A742 0.445kg/m
A792 0.234kg/m 	A793 0.371kg/m 	A824 0.208kg/m 	A828 0.365kg/m
A829 0.359kg/m 	A830 0.416kg/m 	A831L 0.077kg/m 	A832L 0.070kg/m



A857 0.226kg/m 	A852 0.484kg/m 	A853 0.375kg/m 	A856 0.472kg/m
A840 0.377kg/m 	A858 0.159kg/m 	A861 0.379kg/m 	A873 0.603kg/m
A874 0.624kg/m 	A900 0.184kg/m 	A901 0.438kg/m 	A902 0.178kg/m
A904 0.367kg/m 	A905 0.098kg/m 	A912 0.108kg/m 	A913 0.296kg/m

A519 0.385kg/m 	MY038 0.344kg/m 	MY039 0.338kg/m 	MY040 0.085kg/m
MY041 0.067kg/m 	F007A 夹18板 0.21kg/m 	F007B 夹18板 0.26kg/m 	F007-2 0.356kg/m
F007-3 0.486kg/m 	F007-4 0.405kg/m 	F008B 夹18板 0.328kg/m, 0.345kg/m 	F007-5 0.15kg/m
F007-6 0.487kg/m 	F008-1 夹18板 0.289kg/m 	F008-5 0.315kg/m 	F058-3 0.184kg/m

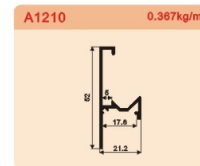
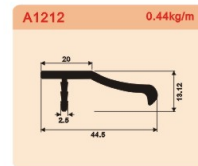
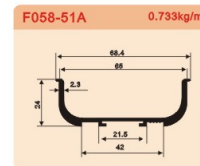
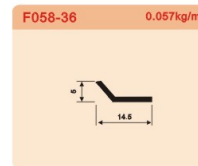
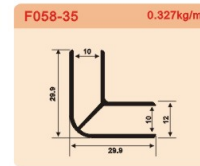
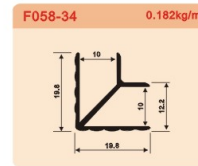
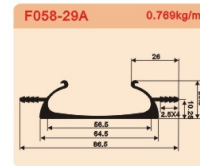
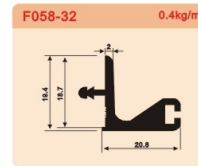
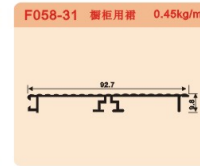
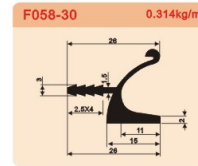
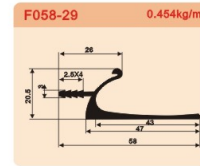
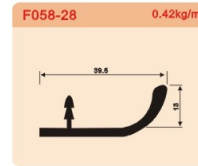
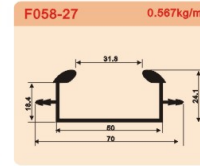
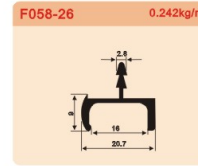
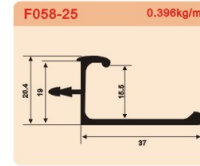
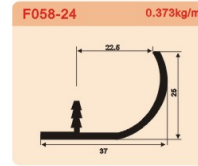
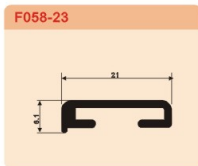
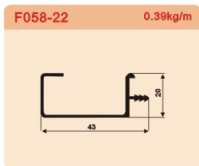
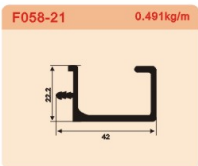
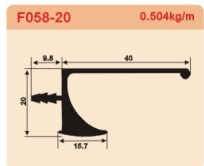
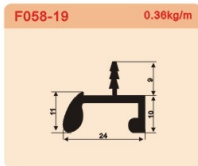
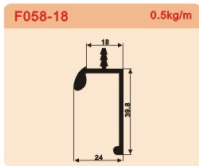
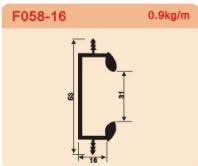
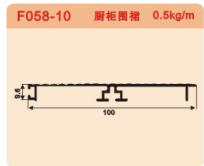
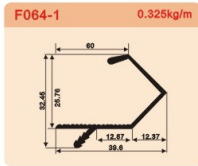
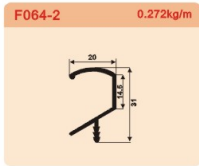
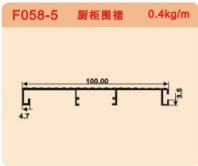
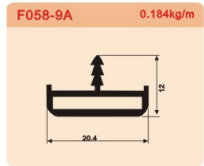
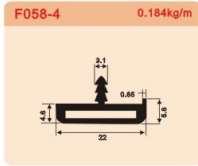
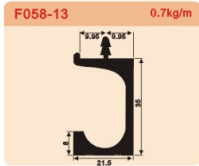
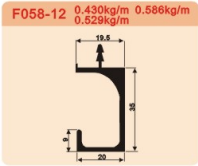
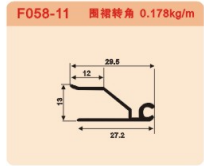



<p>F058-68 0.384kg/m</p>	<p>F058-69</p>	<p>F058-70 0.52kg/m</p>	<p>F058-71 0.36kg/m</p>
<p>F058-72 0.580kg/m</p>	<p>F058-73 0.304kg/m</p>	<p>F058-74 0.528kg/m</p>	<p>F058-75 0.580kg/m</p>
<p>F058-76 0.211kg/m</p>	<p>F058-12A 0.5kg/m</p>	<p>F058-78 0.528kg/m</p>	<p>37板厚台面铝包边条</p> <p>55板厚台面铝包边条</p>
<p>小灯箱搁板一 用铝材: F058-72 F058-73 F058-74</p>	<p>小灯箱搁板二 用铝材: F058-75</p>	<p>小灯箱搁板三 用铝材: F058-81 F058-83</p>	

<p>F058-79 0.393kg/m</p>	<p>F058-80 0.35kg/m</p>	<p>F058-102 0.323kg/m</p> <p>木门铝转边</p>	<p>F058-81 0.853kg/m</p>
<p>F058-12B 0.52kg/m</p>	<p>F058-13A 0.52kg/m</p>	<p>F058-37A 0.887kg/m</p>	<p>F058-37B 0.996kg/m</p>
<p>F0102-90 0.410kg/m</p>	<p>F058-83 0.31kg/m</p>	<p>F058-18A 0.348kg/m</p>	<p>F058-19A 0.260kg/m</p>
<p>F058-84 0.26kg/m</p> <p>玻璃夹条: 铝棒</p>	<p>波纹板铝框门</p>	<p>厨房工作台</p>	

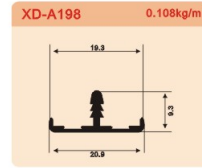
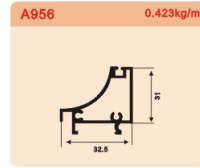
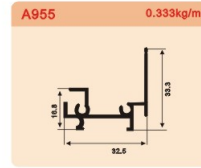
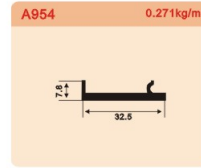
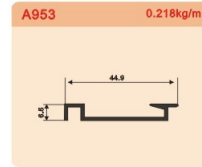
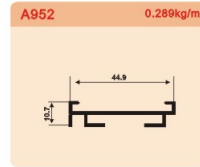
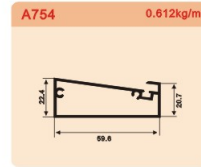
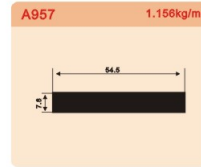
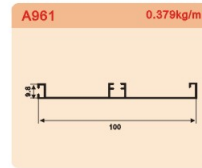
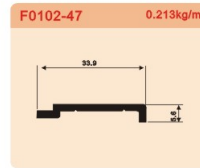
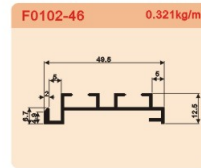
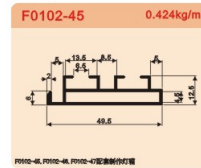
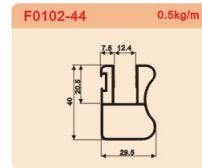
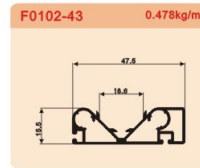
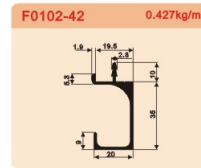
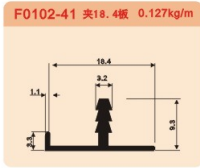
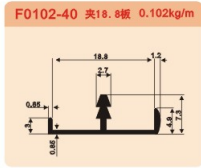
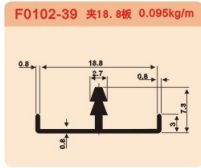
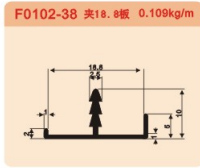
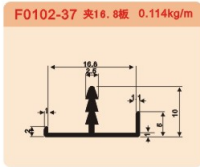
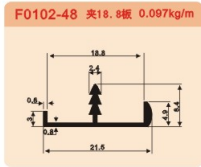
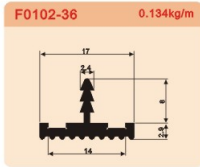
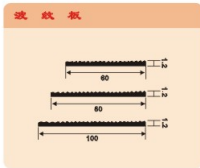
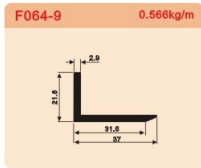
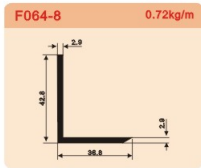
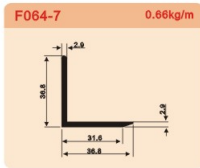
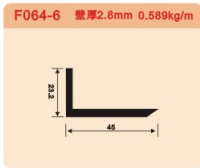
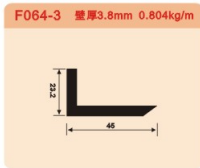

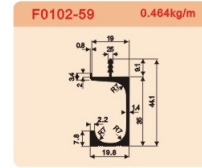
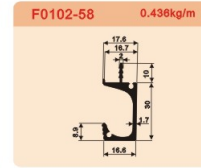
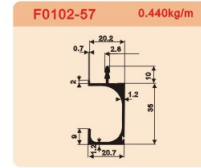
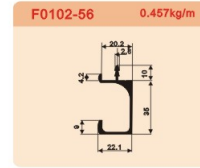
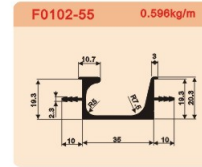
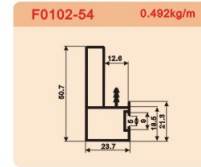
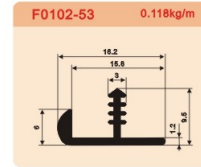
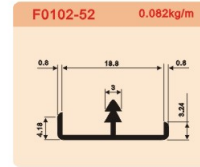
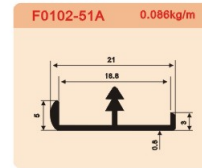
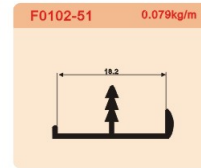
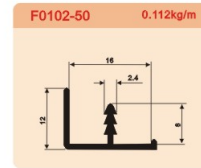
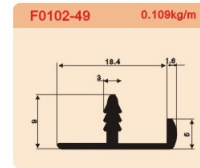
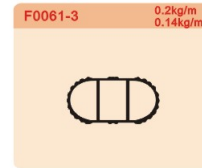
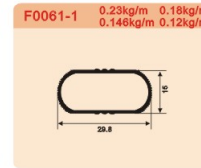
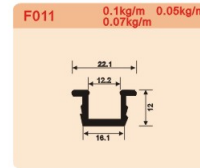
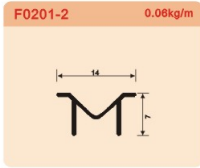
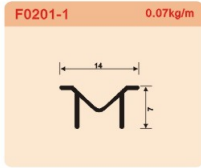
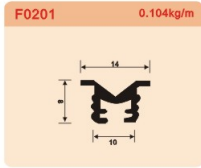
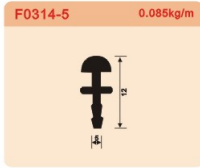
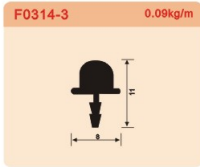
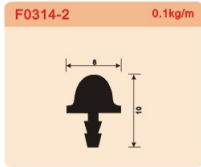
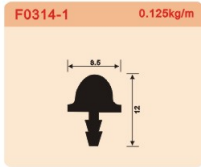
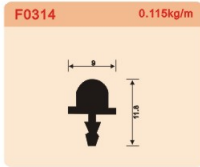
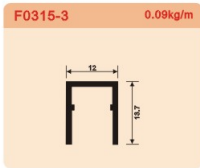
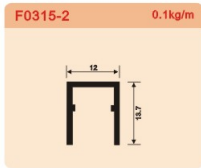
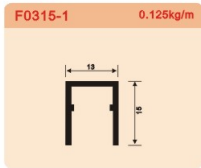
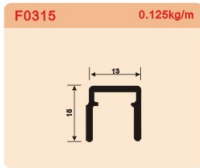
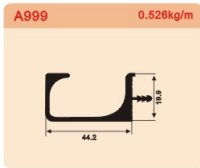
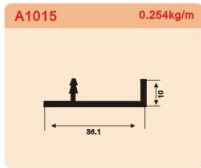
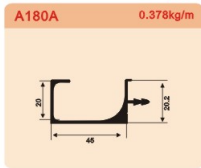
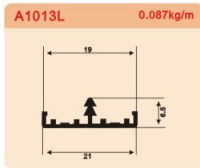

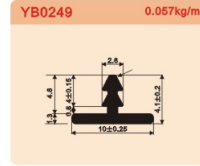
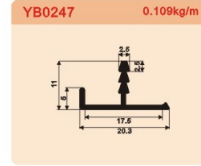
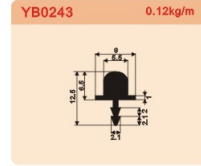
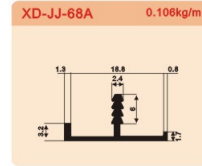
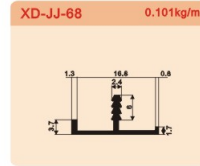
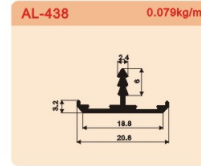
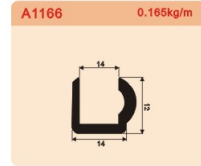
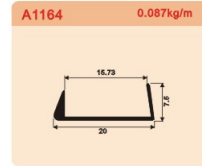
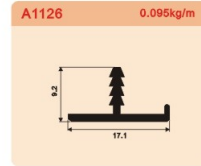
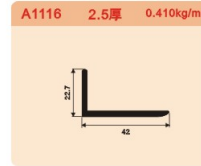
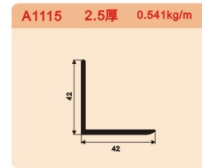
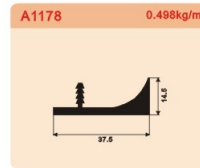
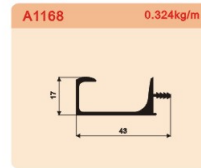
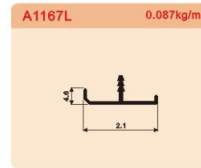
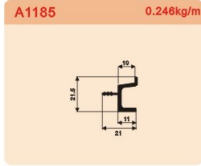
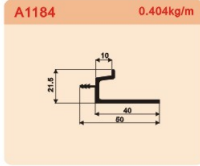
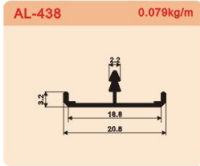
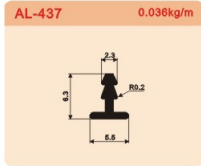
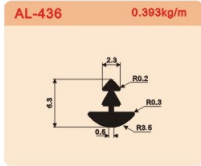
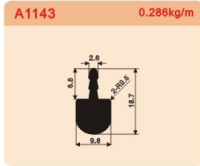
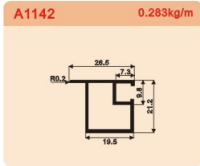
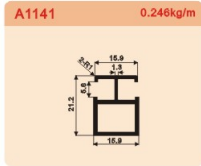
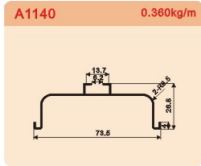
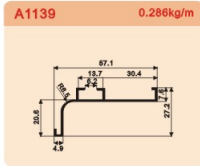
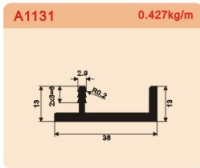
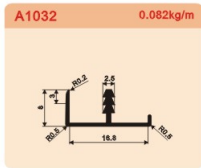
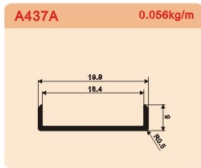
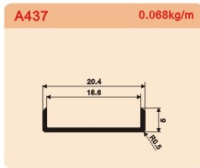

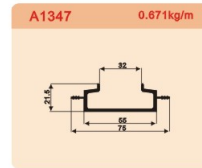
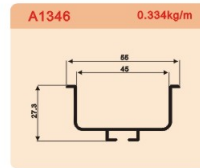
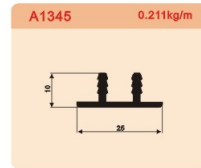
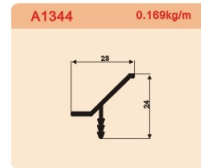
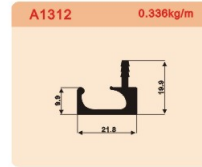
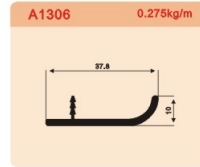
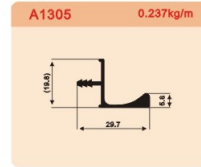
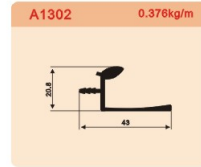
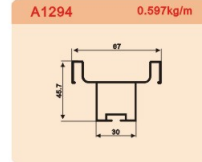
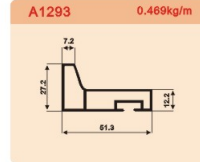
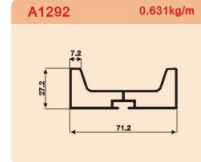
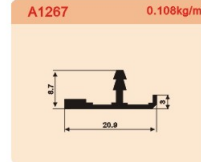
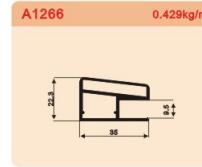
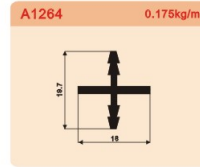
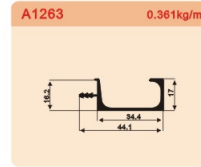
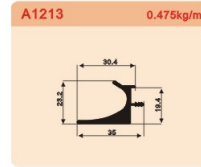
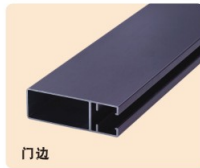
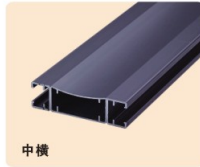
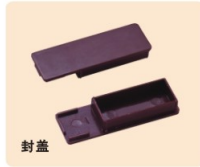
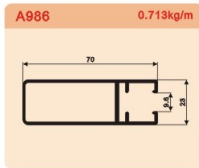
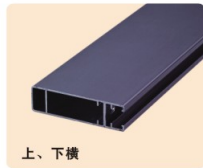
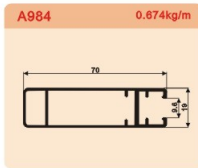
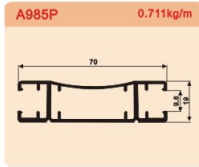
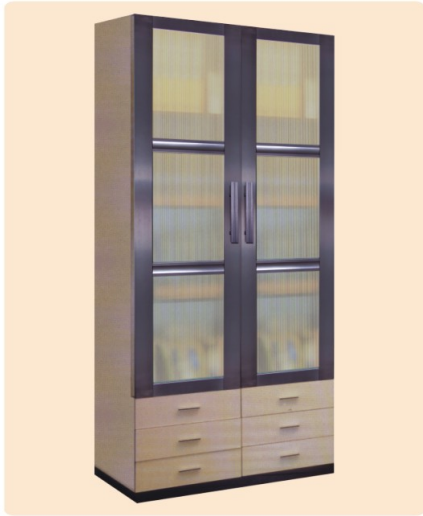



<p>A1348 0.267kg/m</p>	<p>A1364 2.8厚 0.914kg/m</p>	<p>A1391 0.179kg/m</p>	<p>A1395 0.231kg/m</p>
<p>A1396 0.367kg/m</p>	<p>A1397 0.260kg/m</p>	<p>A1398 0.420kg/m</p>	<p>A1400 0.577kg/m</p>
<p>A1535 5.0厚 0.813kg/m</p>	<p>A1536 4.0厚 0.927kg/m</p>	<p>A1539 0.201kg/m</p>	<p>A1014 0.405kg/m</p> <p>配: MY0841</p>
<p>A1016 0.234kg/m</p> <p>配: MY0841</p>	<p>MY0839 0.382kg/m</p> <p>配: MY0480</p>	<p>MY0840 0.093kg/m</p> <p>配: MY0439</p>	<p>MY0841 0.072kg/m</p> <p>配: A1016 A1014</p>



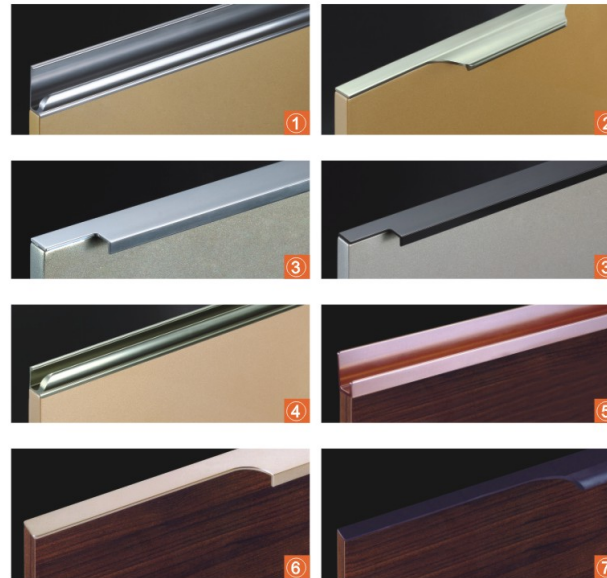



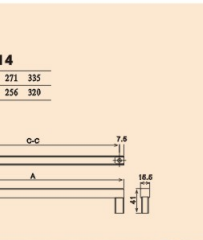
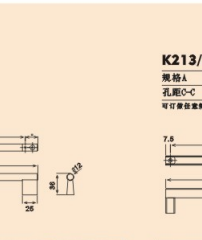
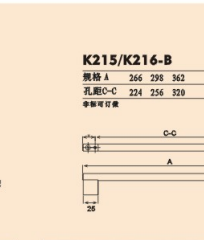
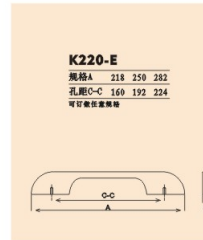
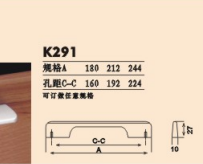
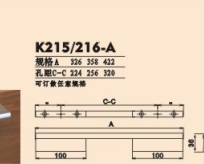
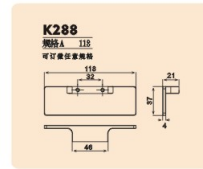
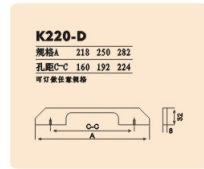
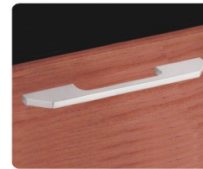
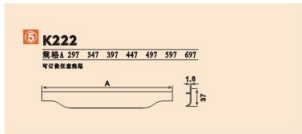
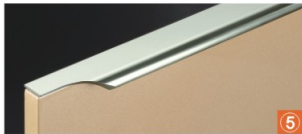
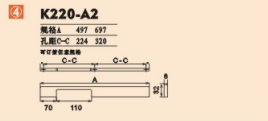
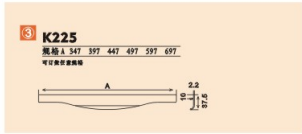

PRECISION METAL 封边拉手

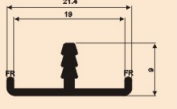
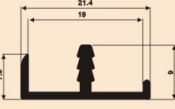
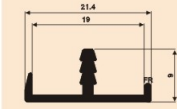
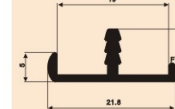
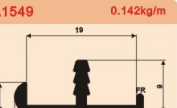

<p>1 K206</p> <p>规格: 347 397 447 397 397 397 397 397</p> <p>可开槽安装</p>	<p>2 K203</p> <p>规格: 347 397 347 447 447 397 397</p> <p>可开槽安装</p>	
<p>3 K201</p> <p>规格: 397 347 347 447 447 447 447 397 397</p> <p>可开槽安装</p>	<p>4 K205</p> <p>规格: 347 397 447 397 397 397 397</p> <p>可开槽安装</p>	<p>5 K287</p> <p>规格: 347 397 447 447 447 347 397 397</p> <p>可开槽安装</p>
<p>6 K224</p> <p>规格: 397 347 347 347 347 347 347 397 397</p> <p>可开槽安装</p>	<p>7 K247</p> <p>规格: 397 347 347 347 347 347 347 397 397</p> <p>可开槽安装</p>	

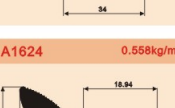

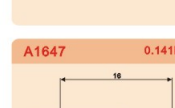
		<p>1 K204 规格 L: 242 352 长度 C-C: 214 324 可开槽长度</p> 	<p>2 K220-A 规格 L: 242 352 长度 C-C: 214 324 可开槽长度</p> 
		<p>3 K220-B2 规格 L: 317 长度 C-C: 215 可开槽长度</p> 	<p>4 K220-C2 规格 L: 317 长度 C-C: 215 可开槽长度</p> 
		<p>5 K220-C1 规格 L: 315 长度 C-C: 214 可开槽长度</p> 	<p>6 K220-B1 规格 L: 315 长度 C-C: 214 可开槽长度</p> 
		<p>8 K219 规格 L: 315 长度 C-C: 214 可开槽长度</p> 	
		<p>7 K218 规格 L: 317 长度 C-C: 214 可开槽长度</p> 	
		<p>9 K217 规格 L: 31 150 长度 C-C: 31 150 可开槽长度</p> 	

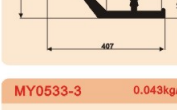
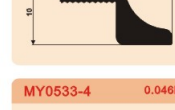
<p>A1545 0.127kg/m</p> 	<p>A1546 0.142kg/m</p> 	<p>A1547 0.1334kg/m</p> 	<p>A1548 0.136kg/m</p> 
<p>A1549 0.142kg/m</p> 	<p>A1597 2.3厚 0.403kg/m</p> 	<p>A1598 2.3厚 0.291kg/m</p> 	<p>A1604 0.387kg/m</p> 
<p>A1605 0.490kg/m</p> 	<p>A1624 0.558kg/m</p> 	<p>A1625 0.447kg/m</p> 	<p>A1647 0.141kg/m</p> 
<p>A1648 2.4厚 0.355kg/m</p> 	<p>A1658 0.215kg/m</p> 	<p>MY0533-3 0.043kg/m</p> 	<p>MY0533-4 0.046kg/m</p> 

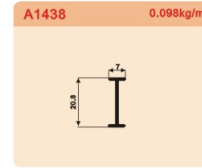
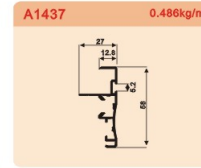
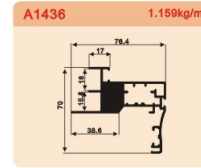
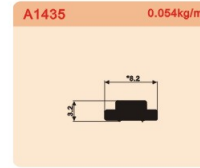
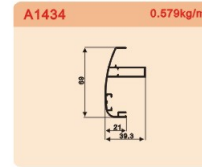
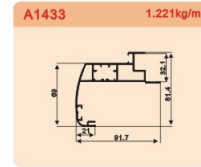
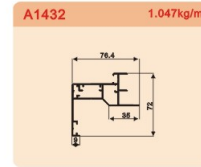
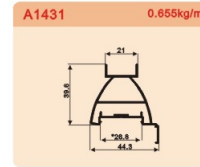
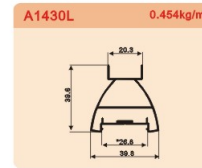
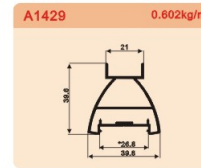
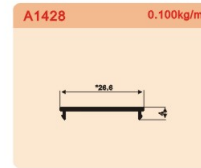
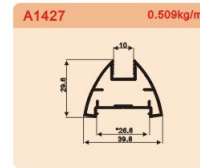
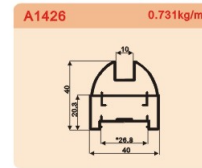
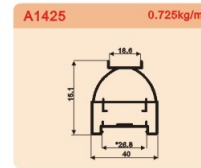
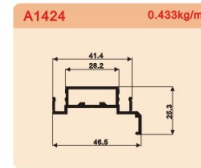
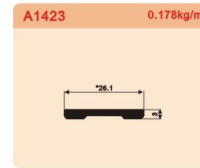
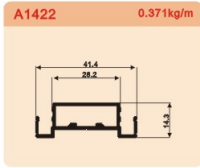
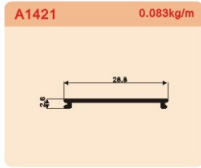
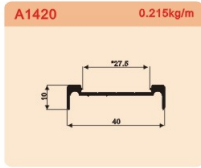
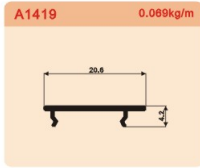
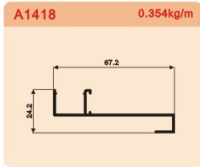
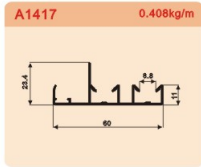
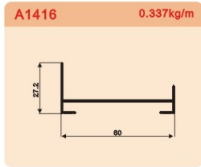
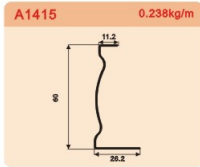
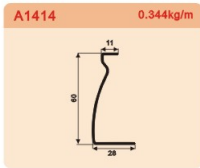
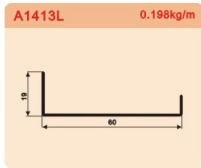
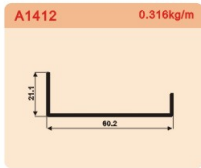
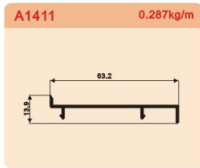
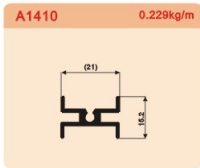
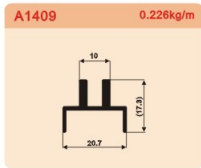
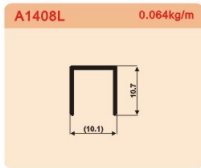
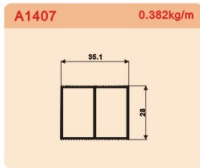

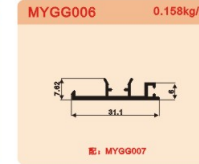
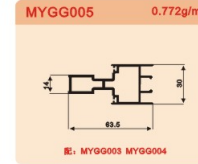
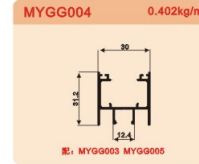
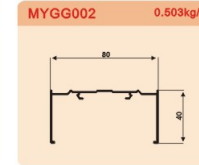
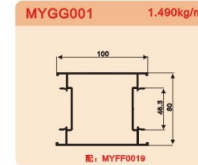
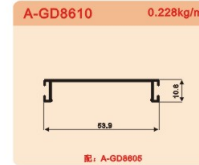
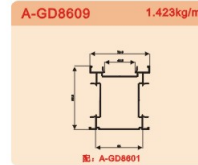
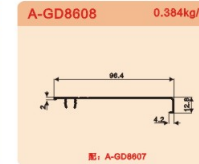
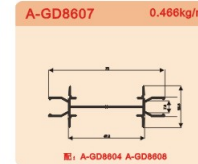
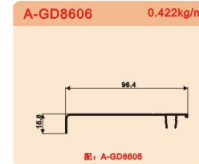
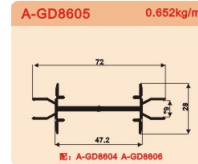
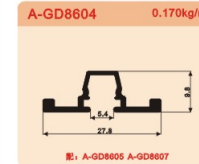
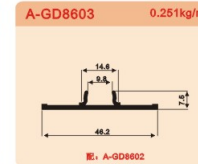
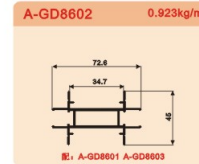
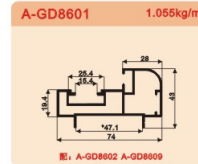
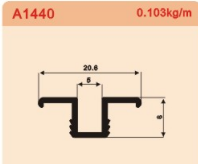
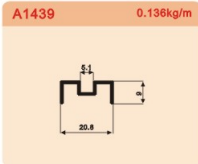

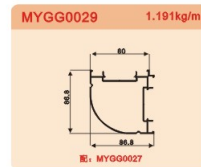
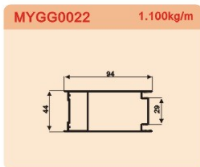
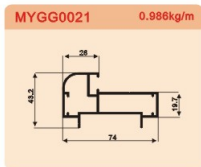
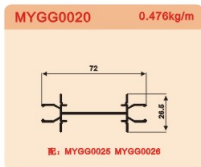
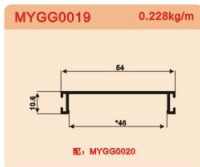
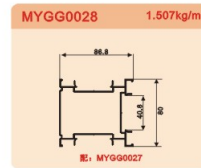
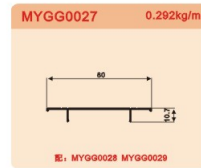
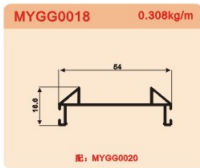
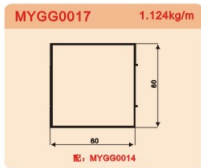
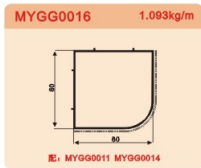
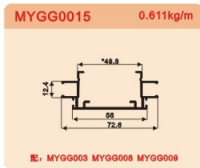
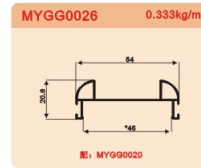
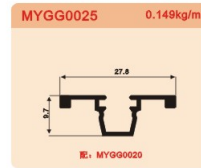
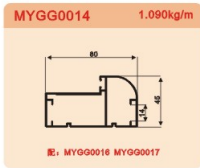
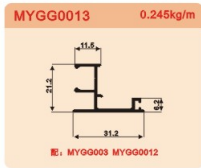
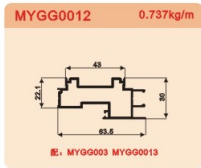
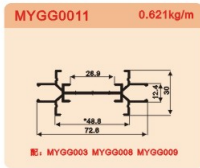
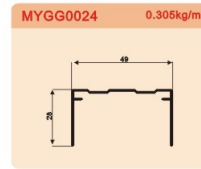
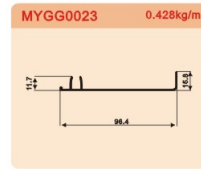
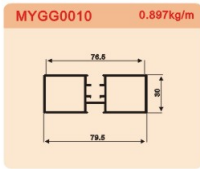
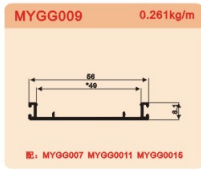
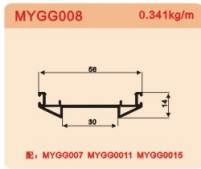
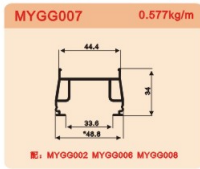



美亚

美亚铝材 MEI YA LV CAI

PRECISION METAL LED灯具系列



产品介绍

LED属于全固体冷光源, 体积更小, 质量更轻, 结构更坚固, 而且工作电压低, 实用寿命长。按照通常的光效定义, LED的发光效率并不高, 但由于LED的光谱几乎全部集中于可见光频段, 效率可达80%~90%。而同等光效的白炽灯的可见效率仅为10%~20%。单体LED的功率一般为0.05~1W, 通过集群方式可以满足不同需求。

PRODUCT INTERPRET

LED's are all solid cold light source, smaller, lighter, stronger structure, And low voltage, practical and long life. According to the usual definition of luminous efficiency, LED's Luminous efficiency is not high, but because LED spectrum almost all concentrated in the visible light spectrum, Efficiency up to 80% to 90%. The equivalent incandescent light efficiency efficiency is only visible 10% to 20%. Single LED power is generally 0.05 ~ 1W, through the cluster approach to meet different needs.

<p>A1565 1.122kg/m</p>	<p>A1566 1.307kg/m</p>	<p>A1567 1.528kg/m</p>	<p>A1568 1.693kg/m</p>
<p>A1569 0.133kg/m</p>	<p>A1570 2.852kg/m</p>	<p>A1571 1.818kg/m</p>	<p>A1572 2.144kg/m</p>
<p>A1575 0.701kg/m</p>	<p>A1628 0.181kg/m</p>	<p>A1629 0.102kg/m</p>	<p>A1575 0.701kg/m</p>
<p>A1628 0.181kg/m</p>			

LED灯具系列 美亚铝材 值得信赖 Mei ya lv cai reliable performance



豪华中空大折叠门系列

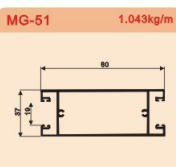
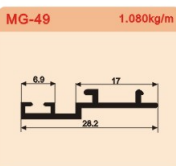
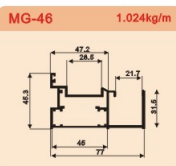
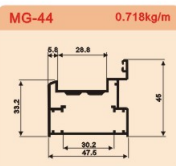
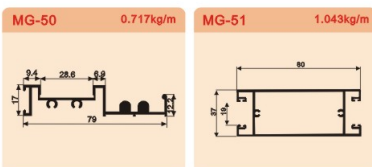
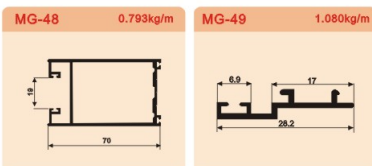
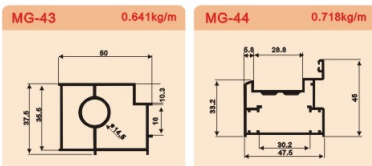

75系列豪华中空推拉门（二轨）

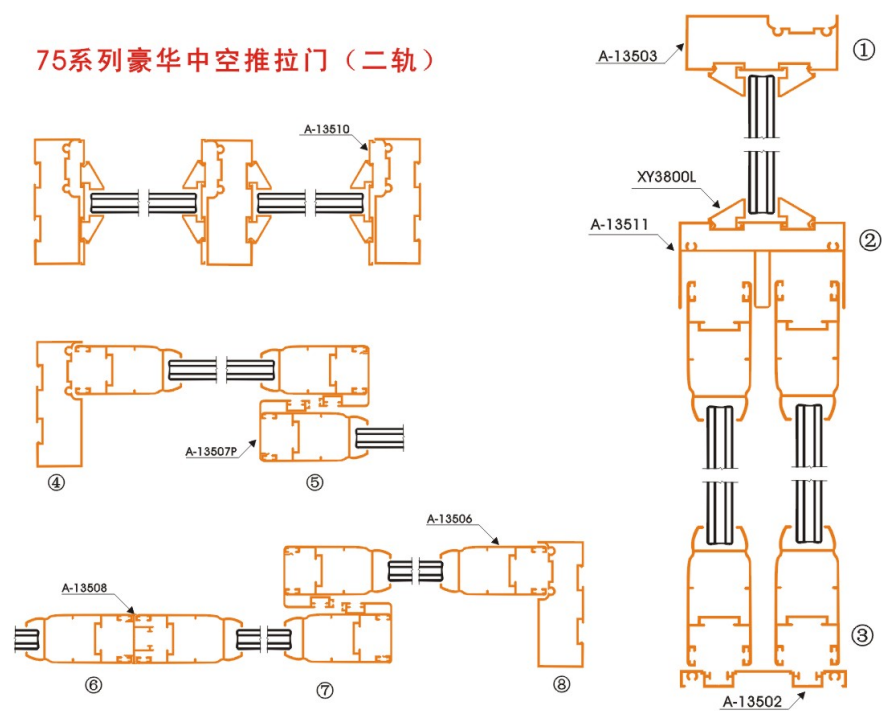



75系列豪华中空推拉门（三轨可配纱扇）

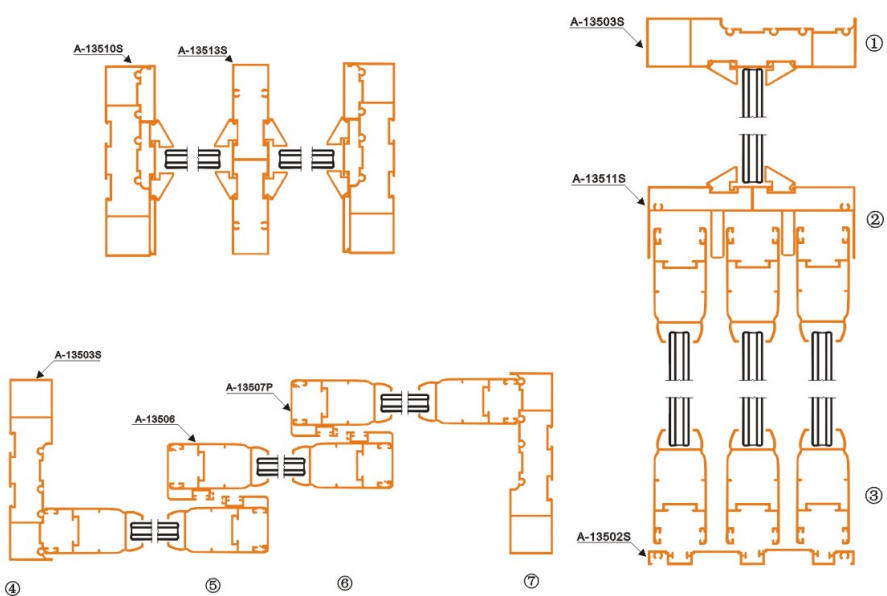

75系列豪华中空吊趟门（三轨可配纱扇）

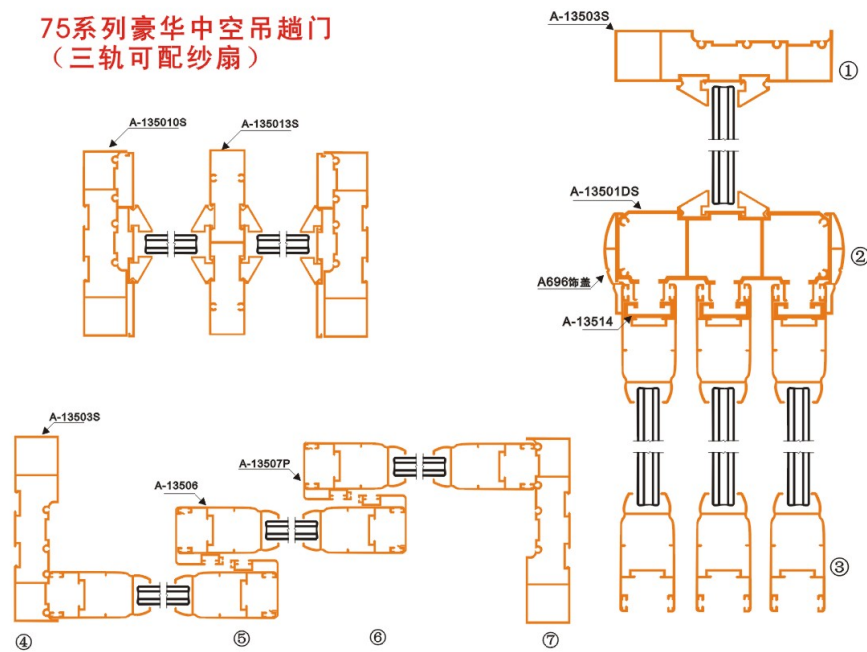



美亚

美亚铝材 MEI YA LV CAI

75系列豪华中空吊趟门 (二轨)

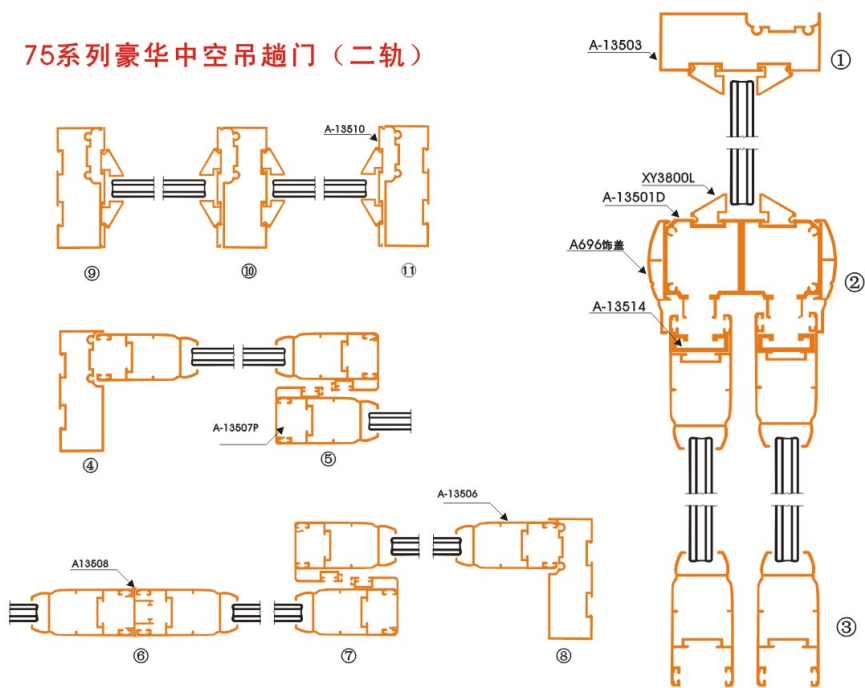

豪华中空75系列推拉
(吊趟)门系列
美亚铝材 ■ 值得信赖

A-13501D	1.938kg/m	A-13501DS	2.697kg/m	A-13502	0.567kg/m
A-13502S	0.801kg/m	A-13503	0.840kg/m	A-13503S	1.429kg/m
A-13507P	0.296kg/m	A-13508	0.241kg/m	A-13510	0.352kg/m
A-13511	1.044kg/m	A-13511S	1.754kg/m	A-13513S	1.344kg/m
				A-13510S	0.557kg/m
				A-13506	0.756kg/m
				A-13514	0.418kg/m

豪华中空推拉门

Mei ya lv cai reliable performance
美亚铝材 ■ 值得信赖



豪华中空银弧大折叠门

(无下轨)

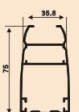
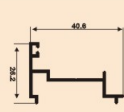
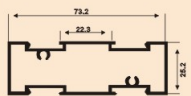
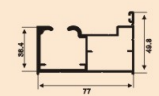
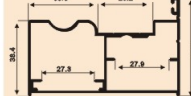
<p>A-D7705 0.982kg/m</p> 		<p>A-D7708 0.273kg/m</p> 	
<p>A-D7713 0.749kg/m</p> 	<p>A-D7701D 1.324kg/m</p> 	<p>A-D7702 1.0284kg/m</p> 	



JC003 (黑胡桃木纹)



折叠门冲压模具(改进型)

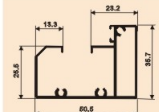
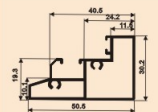
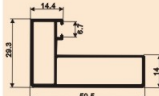
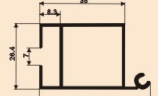
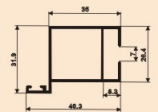
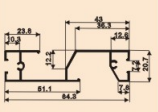
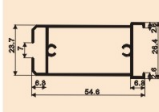
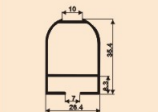
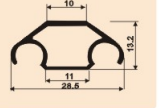
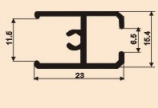
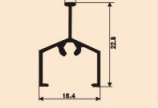
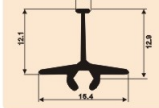
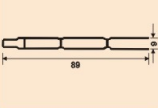

折叠门整套配件

<p>MG-24 上轨 0.62kg/m</p> 		<p>MG-25 下轨 0.590kg/m</p> 	
<p>MG-26 边企 0.629kg/m</p> 	<p>MG-27 勾企 0.435kg/m</p> 	<p>MG-28 勾企(多扇用) 0.437kg/m</p> 	<p>MG-29 中横拉手 0.61kg/m</p> 
<p>MG-30 上、下方 0.518kg/m</p> 	<p>MG-31 光企 0.353kg/m</p> 	<p>MG-32 连接转销 0.46kg/m</p> 	<p>MG-33 百叶上横 0.238kg/m</p> 
<p>MG-34 百叶中横 0.118kg/m</p> 	<p>MG-35 百叶下横 0.108kg/m</p> 	<p>MG-36 扣板</p> 	



美亚

圆弧形小折叠门系列

美亚铝材 ■ 值得信赖

特点:

安装方便, 装饰性更强, 可制做有轨或无轨。

A-ZD7201AL 0.735kg/m



上轨 (带包边)

A-ZD7201L 0.695kg/m

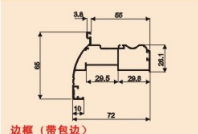

边框 (带包边)

A-ZD7201BL 0.568kg/m



边框 (不带包边)

A-ZD7206L 0.415kg/m

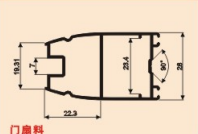

门扇料

A-ZD7201AL 0.735kg/m



上轨 (带包边)

A-ZD7201CL 0.608kg/m

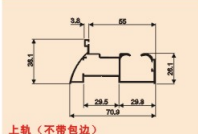

上轨 (不带包边)

A-ZD7205L 0.296kg/m

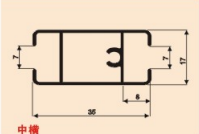

中横

A-ZD7208L 0.161kg/m

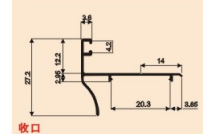

收口

A-ZD7202P 0.299kg/m

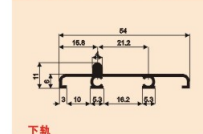

下轨

圆弧形小折叠门整套配件



无下轨型小折叠门

MG-76 带包边上轨

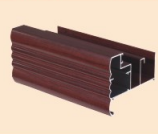

特点:

1. 全部采用了合金配件, 开、关更加轻便和舒畅, 并且极大地提高了使用寿命, 从而结束了小折叠门无高档配件的历史。
2. 新产品采用吊滑轮的新技术, 无槽下轨道, 更加方便清洁卫生和行走。
3. 门框连接部采用了先进的弹簧紧固角码, 使之更牢固耐用。



小折叠门五金



小折叠门拼角

MG-73 不带包边上轨



MG-74 带包边框



MG-75 小折门光企



MG-77 拉手



MG-78 不带包边框

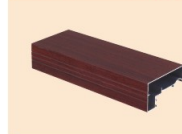

MG-79 上下方 (上、下方通用)

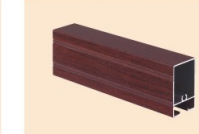



美亚

美亚铝材 MEI YA LV CAI

新型大推拉门系列

特点:

新型大推拉门大量采用了具有防撞及消音功能的PVC塑条, 连接部采用弹簧合金角码及钨钢金属配件, 使产品更完美、更牢固耐用。



新型大推拉门系列



<p>MG-80</p> <p>新型大推拉门三轨上滑、边框</p>	<p>MG-81</p> <p>新型大推拉门边企</p>
<p>MG-82</p> <p>新型大推拉门上滑</p>	<p>MG-83</p> <p>新型三轨下轨</p>
<p>MG-84</p> <p>新型双下轨</p>	<p>MG-85</p> <p>新型大推拉门边企</p>
<p>MG-86</p> <p>新型大推拉门光企 (45度拼角)</p>	<p>MG-87</p> <p>新型大推拉门收口</p>



圆弧系列平开门

<p>MG-63 平开门A型 包边圆弧门框</p>	<p>MG-65 平开门A型 无包边圆弧门框</p>	<p>MG-64 平开门A型 圆弧光企</p>
<p>A型圆弧光企角码宽度32mm B型圆弧光企角码宽度37mm C型圆弧光企角码宽度37mm</p> <p>MG-67 平开门B型 圆弧门框</p>	<p>MG-69 平开门B型 圆弧光企</p>	
<p>塑料配件 平开门A型, B型, C型 通用</p> <p>MG-88 平开门C型 包边圆弧门框</p>	<p>平衡铁片配件 平开门B型, C型通用</p> <p>MG-89 平开门C型 圆弧光企</p>	<p>外包边</p>



<p>MG-08 平开门D型 圆弧门框</p>	<p>MG-08A 平开门D型 圆弧门框</p>	<p>MG-41 平开门D型 93光企</p>	<p>D型配件</p> <p>门扇加固配件</p>
<p>MG-92 平开门E型 包边圆弧门框</p>	<p>MG-93 平开门E型 无包边圆弧门框</p>	<p>MG-94 平开门E型 圆弧光企</p>	<p>E型圆弧光企 角码宽度25mm</p>
<p>MG-90 平开门F型 圆弧门框</p>	<p>MG-91 平开门F型 圆弧光企</p>	<p>加固配件 平开门E型, F型 适用</p> <p>平衡铁片配件 平开门E型, F型 适用</p> <p>F型圆弧光企 角码宽度33mm F型圆弧门框 角码宽度32mm</p>	

<p>MG-72 平开门G型 内包边</p>	<p>MG-72A 平开门G型 内包边</p>	<p>MG-72B 平开门G型 门框</p>	<p>平开门G型专用配件</p>
<p>MG-41 平开门G型 93光企</p>	<p>MG-41A 平开门G型 96光企</p>	<p>MG-89 平开门H型 无包边带筋门框</p>	<p>MG-41 平开门H型 93光企</p>
<p>A525 0.071kg/m</p>	<p>A526 0.053kg/m</p>	<p>SEM061P 0.095kg/m</p>	<p>A525</p> <p>SEM061P</p> <p>A526</p>

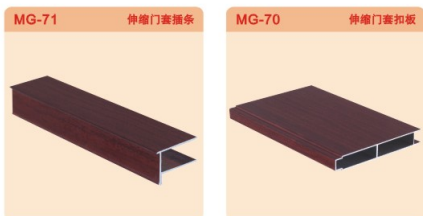
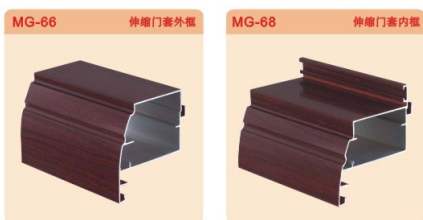

特点：不受墙体尺寸限制，无限延伸。产品采用锰钢配件和弹簧合金角码组装，使产品更加牢固和便于安装。

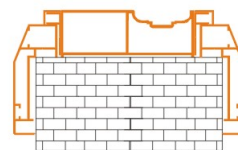

多功能门包套

特点：不受墙体限制，任意加宽，安装简易，可以和任何门类配套，外观简洁，独特的表面处理工艺，使产品更加完美。

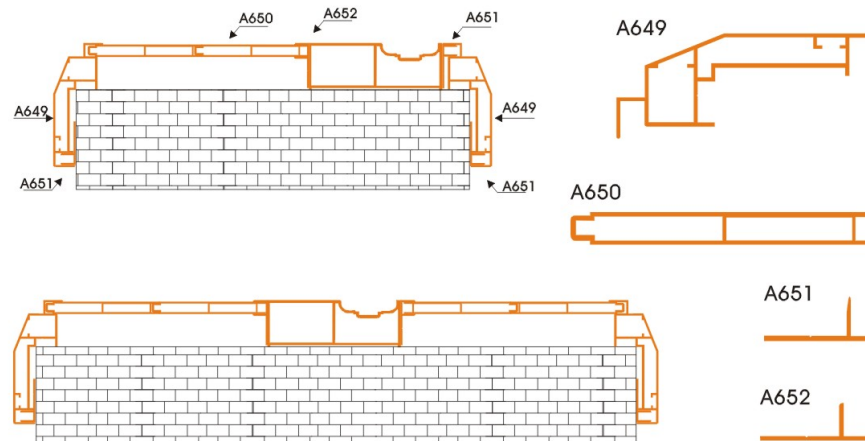
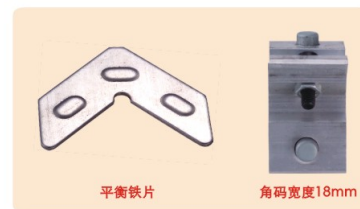



美亚

美亚铝材 MEI YA LV CAI

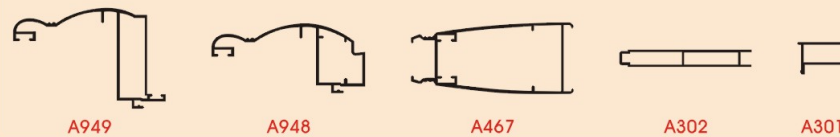
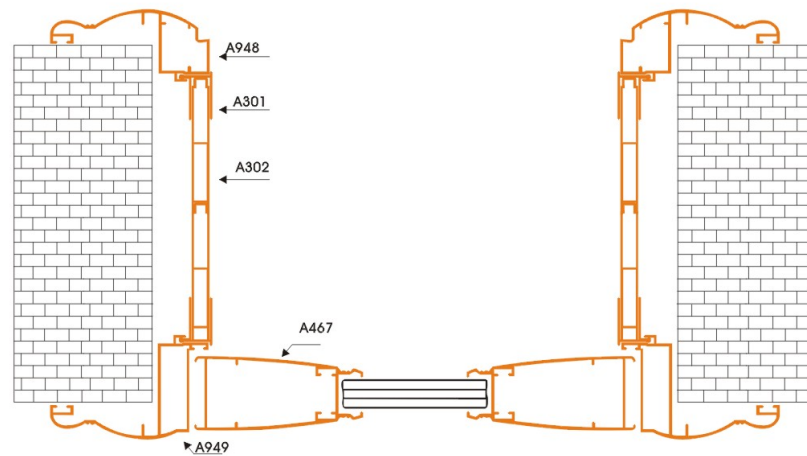
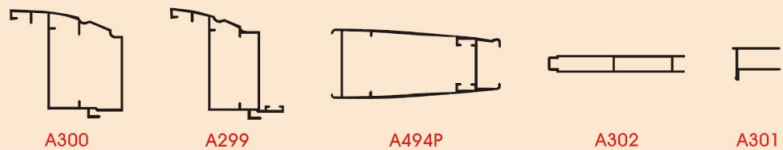
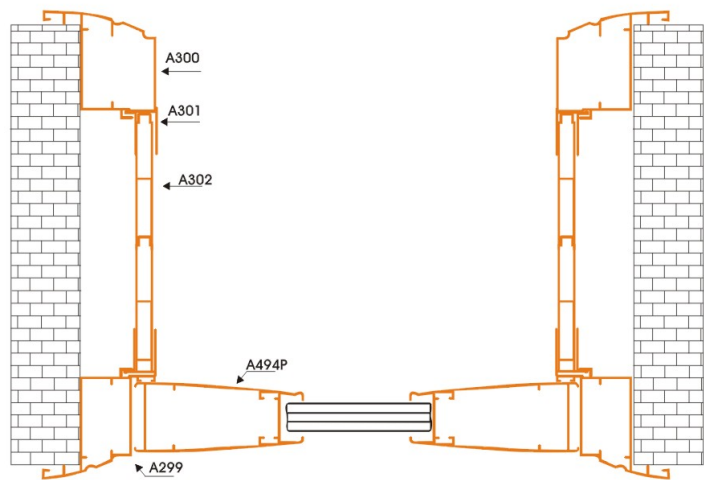

多功能包套系列

美亚铝材 Mei Ya Lv Cai reliable performance 值得信赖

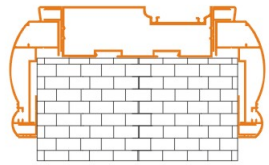

安装方式一

A650

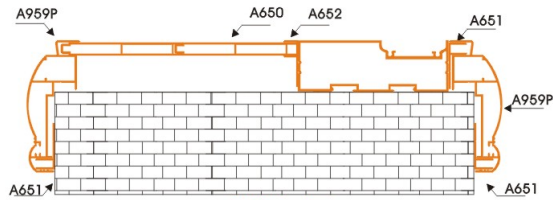

安装方式二

A959P

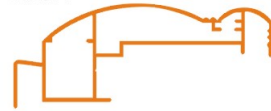

A651

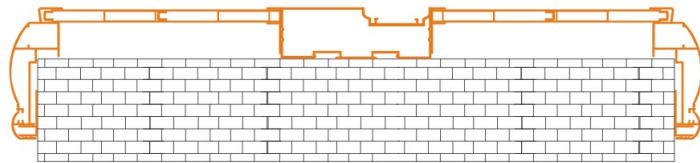

安装方式三

A652





<p>A-M8802 0.561Kg/m</p>	<p>A-M8803P 0.757kg/m</p>	<p>A-M8806AP 0.895kg/m</p>	<p>A-M8806P 0.764kg/m</p>
<p>A-M8807AP 0.276kg/m</p>	<p>A-M8807P 0.283kg/m</p>	<p>A-M8808P 0.246kg/m</p>	<p>A-M8809 0.235kg/m</p>
<p>A-M8810P 0.315kg/m</p>	<p>A-M8811D 2.093kg/m</p>	<p>A-M8811T 1.403kg/m</p>	<p>A-M8813P 0.711kg/m</p>



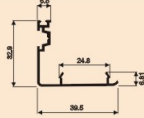
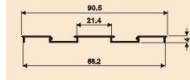
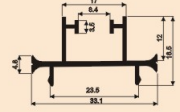
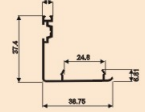
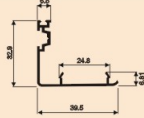

美亚铝材 MEI YA LV CAI

经济型70、80系列 推拉门

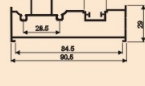
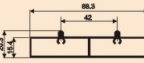
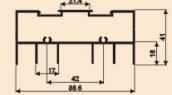
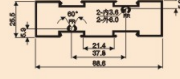
Meiya's reliable performance
美亚铝材 ■ 值得信赖

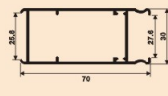
<p>A-M9007AP 0.265kg/m</p> 	<p>A-M9010L 0.282kg/m</p> 	<p>A-M9008P 0.253kg/m</p> 	<p>A-M9007P 0.269kg/m</p> 
<p>A-M9007AP 0.265kg/m</p> 	<p>A-M9006P 0.766kg/m</p> 	<p>A-M9006AP 0.690kg/m</p> 	<p>A-M9003P 0.827kg/m</p> 
<p>A-M9002P 0.753kg/m</p> 	<p>A-M9001P 0.883kg/m</p> 	<p>A-M9013P 0.716kg/m</p> 	

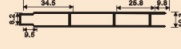
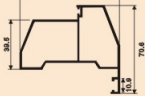
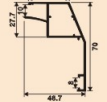
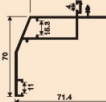
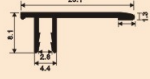
<p>A1086 0.55kg/m</p> 	<p>A1084 0.839kg/m</p> 	<p>A1085L 0.510kg/m</p> 	<p>A1083 0.839kg/m</p> 
<p>A1059P 0.467kg/m</p> 	<p>A1060P 0.502kg/m</p> 	<p>A1061L 0.087kg/m</p> 	



欧式衣帽间系列
Meiya lv cai reliable performance
美亚铝材 ■ 值得信赖

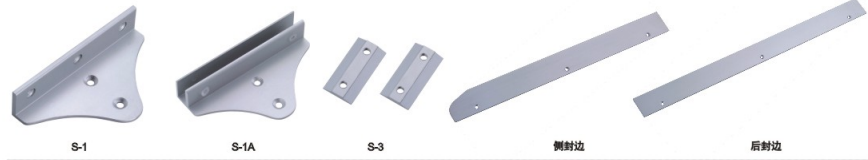
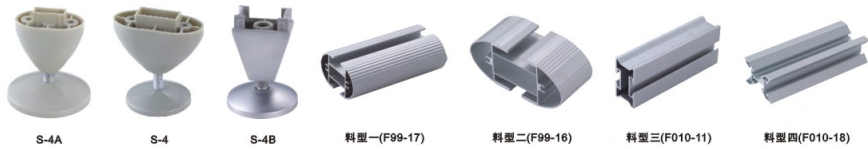

Item no.订货号	Length(mm)长度
F010-18	4800
F99-17	4800
F99-16	4800
F010-11	4800
侧封边	300-500-600
后封边	400-600-800-900
S-5	95-180-260-310 (Φ10)
S-5A	95-180-260-310 (Φ10)
S-5B	95-180-260-310 (Φ10)

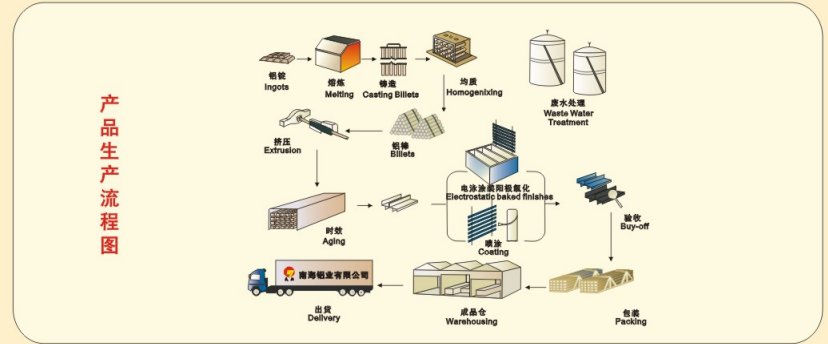

产品牌号、状态和规格

牌号	供应状态	规格	
		外接圆外径	供应长度mm
6063	T5	≤250	6020

铝合金化学成分对比

标准	化学成分 (%)									
	Mg 镁	Si 硅	Mn 锰	Fe 铁	Cu 铜	Zn 锌	Cr 铬	Ti 钛	其他杂质	Al
南海 QYY B03/01-2000	0.50 ~0.8	0.30 ~0.50	≤0.05	≤0.25	≤0.05	≤0.05	≤0.05	≤0.10	总和≤0.15	余量
中国 Gb319	0.45 ~0.9	0.20 ~0.6	≤0.10	≤0.35	≤0.10	≤0.10	≤0.10	≤0.10	总和≤0.15	余量
日本 JSH41400	0.45 ~0.9	0.20 ~0.6	≤0.10	≤0.35	≤0.10	≤0.10	≤0.10	≤0.10	总和≤0.15	余量